

DTH HAMMER

KSS425 19" HAMMER WITH SD18 SHANK

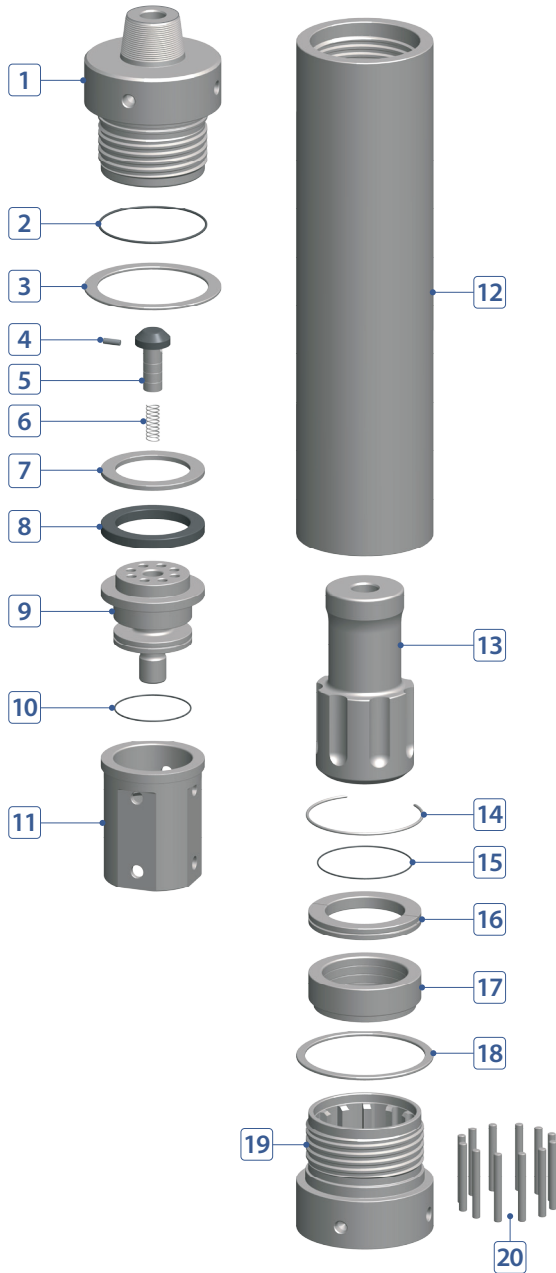

COMPONENT PART



No.	DESCRIPTION	Q'TY	PART #
1	Back Head	1	K190-02-A01HRP
2	Back Head O-Ring	1	K190-02-A03000
3	Back Head Washer	1	K190-02-A02000
4	Plug (Choke)	1	K190-02-A08000
5	Air Check Valve	1	K190-02-A09000
6	Air Check Valve Spring	1	K190-02-A10000
7	Buffering Washer (Steel)	1	K190-02-A05000
8	Buffering	1	K190-02-A07000
9	Air Distributor	1	K190-02-A15000
10	Air Distributor O-Ring	1	K190-02-A16000
11	Cylinder	1	K190-02-A17000
12	Wear Sleeve	1	K190-02-A25SDK
13	Piston	1	K190-02-A26SDK
14	Piston Stop Ring (Key)	1	K190-02-A29000
15	Bit Retainer O-Ring	1	K190-02-A37000
16	Bit Retainer	1	K190-02-A36SDK
17	Guide Sleeve	1	K190-02-A38SDK
18	Chuck Washer	1	K190-02-A39000
19	Chuck	1	K190-02-A41SDK
20	Drive Pin	12	K190-02-A44SDK

HAMMER SPECIFICATIONS

Length (w/o drill bit)	70.78"	1,798 mm
Outside Diameter	16.73"	425 mm
Weight	3,589 lbs.	1,628 kg
Piston Weight	498.7 lbs.	226.2 kg
Hole Size	18-3/8"~26-3/8"	467 ~ 670 mm
Connection	Std. 8-5/8" API Reg Pin	

AIR CONSUMPTION CHART

