

DTH HAMMER

KSS360 16" HAMMER WITH SD15 SHANK

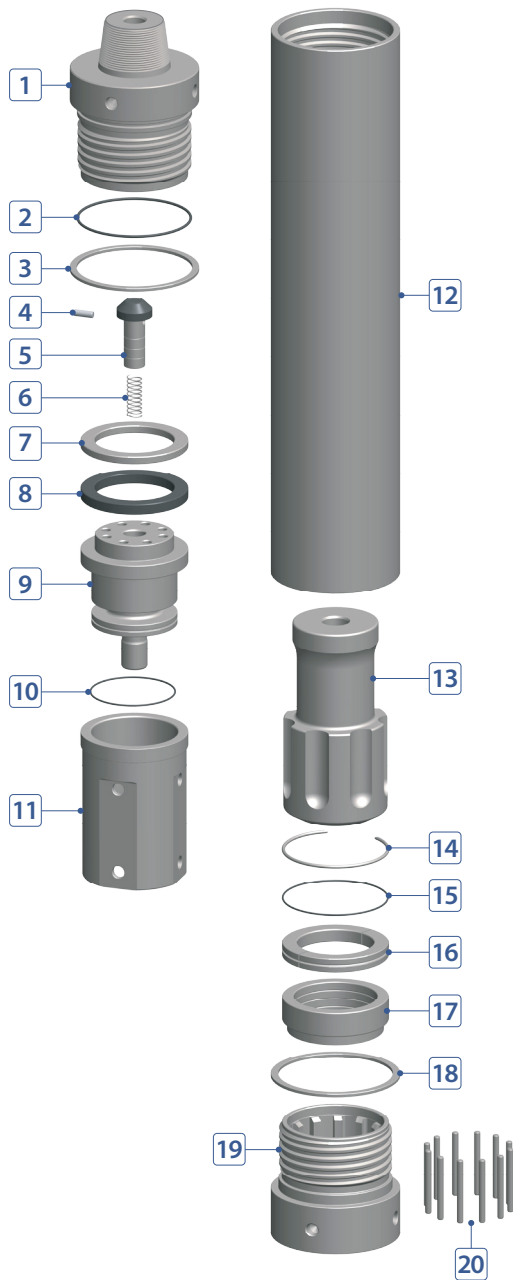

COMPONENT PART



No.	DESCRIPTION	Q'TY	PART #
1	Back Head	1	K160-02-A01HRP
2	Back Head O-Ring	1	K160-02-A03000
3	Back Head Washer	1	K160-02-A02000
4	Plug (Choke)	1	K160-02-A08000
5	Air Check Valve	1	K160-02-A09000
6	Air Check Valve Spring	1	K160-02-A10000
7	Buffering Washer (Steel)	1	K160-02-A05000
8	Buffering	1	K160-02-A07000
9	Air Distributor	1	K160-02-A15000
10	Air Distributor O-Ring	1	K160-02-A16000
11	Cylinder	1	K160-02-A17000
12	Wear Sleeve	1	K160-02-A25SDK
13	Piston	1	K160-02-A26SDK
14	Piston Stop Ring (Key)	1	K160-02-A29SDK
15	Bit Retainer O-Ring	1	K160-02-A37000
16	Bit Retainer	1	K160-02-A36SDK
17	Guide Sleeve	1	K160-02-A38SDK
18	Chuck Washer	1	K160-02-A39000
19	Chuck	1	K160-02-A41SDK
20	Drive Pin	12	K160-02-A44SDK

HAMMER SPECIFICATIONS

Length (w/o drill bit)	73.18"	1,859 mm
Outside Diameter	14.17"	360 mm
Weight	2,392 lbs.	1,085 kg
Piston Weight	445 lbs.	202 kg
Hole Size	16" ~ 22"	406 ~ 560 mm
Connection	Std. 8-5/8" API Reg Pin	

AIR CONSUMPTION CHART

