

# DTH HAMMER

## KSN510 24" HAMMER WITH NUMA240 SHANK

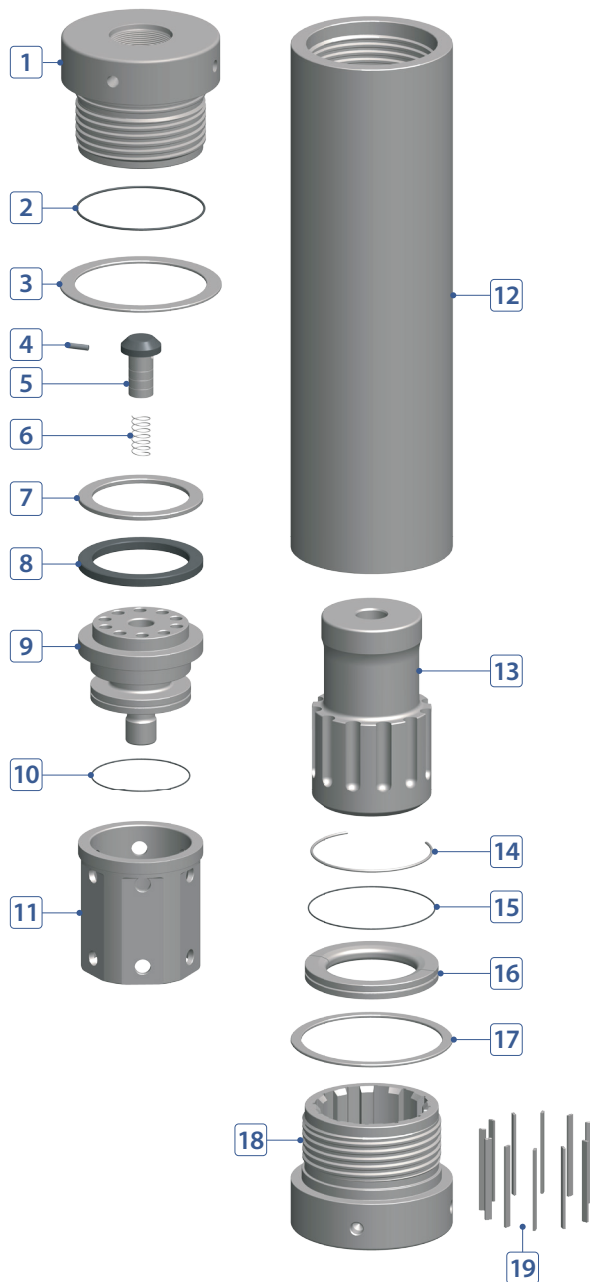

### COMPONENT PART



No.	DESCRIPTION	Q'TY	PART #
1	Back Head	1	K240-02-A0124H
2	Back Head O-Ring	1	K240-02-A03000
3	Back Head Washer	1	K240-02-A02NUM
4	Plug (Choke)	1	K240-02-A08000
5	Air Check Valve	1	K240-02-A09000
6	Air Check Valve Spring	1	K240-02-A10000
7	Buffering Washer (Steel)	1	K240-02-A05000
8	Buffering	1	K240-02-A07000
9	Air Distributor	1	K240-02-A15000
10	Air Distributor O-Ring	1	K240-02-A16000
11	Cylinder	1	K240-02-A17000
12	Wear Sleeve	1	K240-02-A25NUM
13	Piston	1	K240-02-A26000
14	Piston Stop Ring (Key)	1	K240-02-A29000
15	Bit Retainer O-Ring	1	K240-02-A37000
16	Bit Retainer	1	K240-02-A36000
17	Chuck Washer	1	K240-02-A39NUM
18	Chuck	1	K240-02-A41NUM
19	Drive Pin	12	K240-02-A44000

### HAMMER SPECIFICATIONS

Length (w/o drill bit)	78"	1,982 mm
Outside Diameter	20"	510 mm
Weight	5,200 lbs.	2,359 kg
Piston Weight	910.5 lbs.	413 kg
Hole Size	23.2" ~ 34"	590 ~ 864 mm
Connection	Std. Hexagon 240H	

### AIR CONSUMPTION CHART

