

# DTH HAMMER

## KSN425 19" HAMMER WITH NUMA180 SHANK

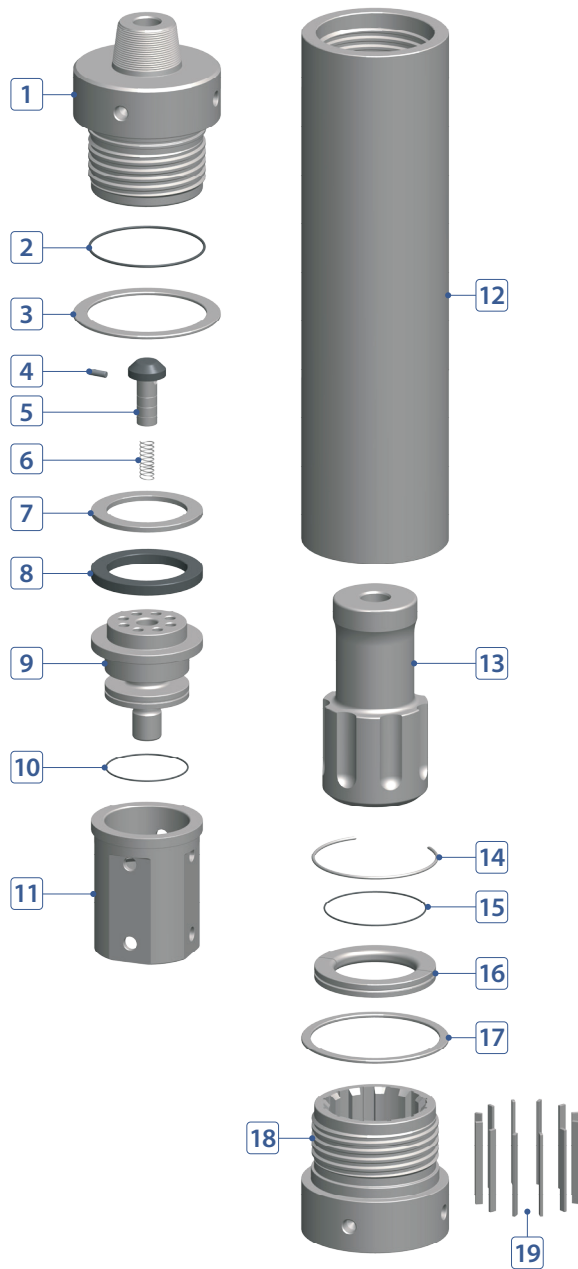

### COMPONENT PART



No.	DESCRIPTION	Q'TY	PART #
1	Back Head	1	K190-02-A01HRP
2	Back Head O-Ring	1	K190-02-A03000
3	Back Head Washer	1	K190-02-A02000
4	Plug (Choke)	1	K190-02-A08000
5	Air Check Valve	1	K190-02-A09000
6	Air Check Valve Spring	1	K190-02-A10000
7	Buffering Washer (Steel)	1	K190-02-A05000
8	Buffering	1	K190-02-A07000
9	Air Distributor	1	K190-02-A15000
10	Air Distributor O-Ring	1	K190-02-A16000
11	Cylinder	1	K190-02-A17000
12	Wear Sleeve	1	K190-02-A25NUM
13	Piston	1	K190-02-A26NUM
14	Piston Stop Ring (Key)	1	K190-02-A29000
15	Bit Retainer O-Ring	1	K190-02-A37000
16	Bit Retainer	1	K190-02-A36NUM
17	Chuck Washer	1	K190-02-A39000
18	Chuck	1	K190-02-A41NUM
19	Drive Pin	12	K190-02-A44NUM

### HAMMER SPECIFICATIONS

Length (w/o drill bit)	67.87"	1,724 mm
Outside Diameter	16.73 "	425 mm
Weight	3,510 lbs.	1,592 kg
Piston Weight	497.8 lbs.	225.8 kg
Hole Size	18-3/8"~26-3/8"	467 ~ 670 mm
Connection	Std. 8-5/8" API Reg Pin	

### AIR CONSUMPTION CHART

