

DTH HAMMER

KSN320 15" HAMMER WITH NUMA125 SHANK

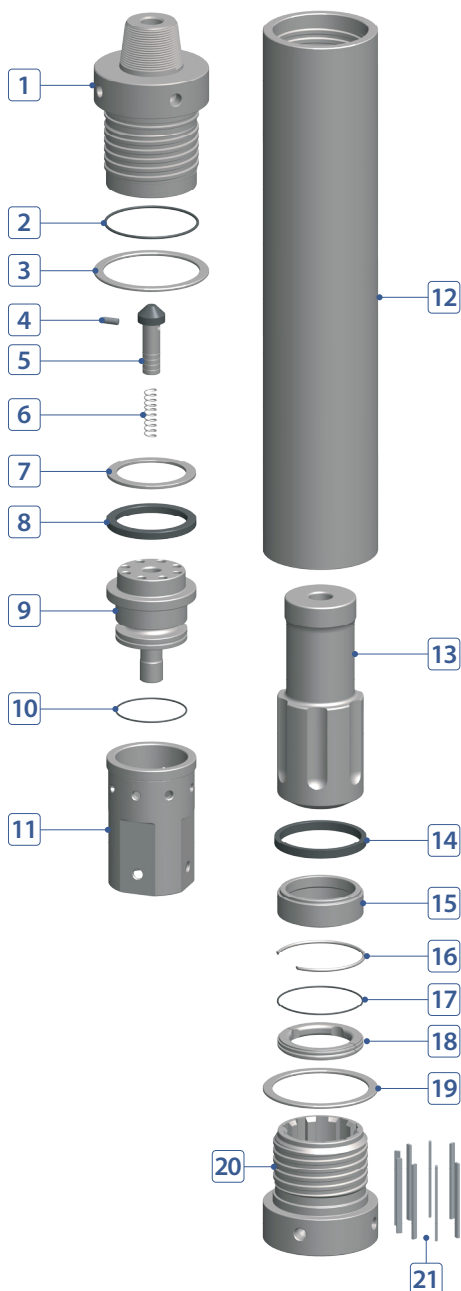

COMPONENT PART



No.	DESCRIPTION	Q'TY	PART #
1	Back Head	1	K150-02-A01GRP
2	Back Head O-Ring	1	K150-02-A03000
3	Back Head Washer	1	K150-02-A02000
4	Plug (Choke)	1	K150-02-A08000
5	Air Check Valve	1	K150-02-A09000
6	Air Check Valve Spring	1	K150-02-A10000
7	Buffering Washer (Steel)	1	K150-02-A05000
8	Buffering	1	K150-02-A07000
9	Air Distributor	1	K150-02-A15000
10	Air Distributor O-Ring	1	K150-02-A16000
11	Cylinder	1	K150-02-A17000
12	Wear Sleeve	1	K150-02-A25NUM
13	Piston	1	K150-02-A26NUM
14	Piston Stop Ring (Buffering)	1	K150-02-A28000
15	Bearing	1	K150-02-A31NUM
16	Bearing Stop Ring (Key)	1	K150-02-A34NUM
17	Bit Retainer O-Ring	1	K150-02-A37000
18	Bit Retainer	1	K150-02-A36NUM
19	Chuck Washer	1	K150-02-A39000
20	Chuck	1	K150-02-A41NUM
21	Drive Pin	10	K150-02-A44NUM

HAMMER SPECIFICATIONS

Length (w/o drill bit)	69.4"	1,763 mm
Outside Diameter	12.6"	320 mm
Weight	1,889.4 lbs.	857 kg
Piston Weight	337.3 lbs.	153 kg
Hole Size	15" ~ 20"	380 ~ 508 mm
Connection	Std. 7-5/8" API Reg Pin	

AIR CONSUMPTION CHART

