

DTH HAMMER

WCS801 8" HAMMER WITH SD8 SHANK



[NO FOOT VALVE TYPE]

COMPONENT PART

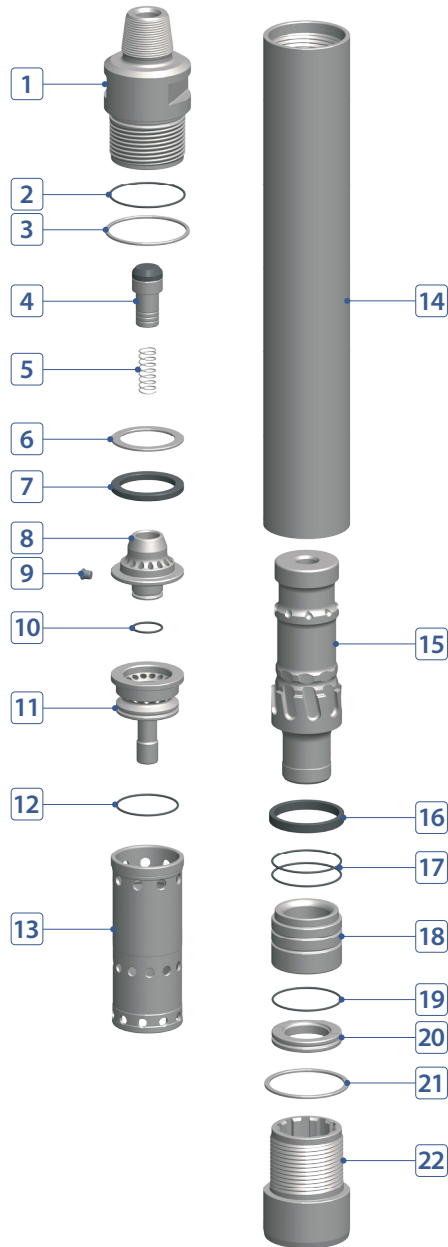

No.	DESCRIPTION	Q'TY	PART #
1	Back Head	1	T080-02-A01DRP
2	Back Head O-Ring	1	T080-02-A03000
3	Back Head Washer	1	T080-02-A02000
4	Air Check Valve	1	T080-02-A09000
5	Air Check Valve Spring	1	T080-02-A10000
6	Buffering Washer	1	T080-02-A05000
7	Buffering	1	T080-02-A07000
8	Air Guide	1	T080-02-A11000
9	Air Guide Plug (Choke)	1	T080-02-A13000
10	Air Guide O-Ring	1	T080-02-A14000
11	Air Distributor	1	T080-02-A15000
12	Air Distributor O-Ring	1	T080-02-A16000
13	Cylinder	1	T080-02-A17000
14	Wear Sleeve	1	T080-02-A25000
15	Piston	1	T080-02-A26SMK
16	Piston Stop Ring	1	T080-02-A28000
17	Bearing O-Ring	2	T080-02-A32000
18	Bearing	1	T080-02-A31SDK
19	Bit Retainer O-Ring	1	T080-02-A37000
20	Bit Retainer	1	T080-02-A36SDK
21	Chuck Washer	1	T080-02-A39000
22	Chuck	1	T080-02-A41SDK

HAMMER SPECIFICATIONS

Length (w/o drill bit)	50.82"	1,291 mm
Outside Diameter	7.28"	185 mm
Weight	428.8 lbs.	194.5 kg
Piston Weight	94.7 lbs.	43 kg
Hole Size	7-7/8" ~ 10"	200 ~ 254 mm
Connection	Std. 4-1/2" API Reg Pin	

AIR CONSUMPTION CHART

