

DTH HAMMER

WCS80 8" HAMMER WITH SD8 SHANK

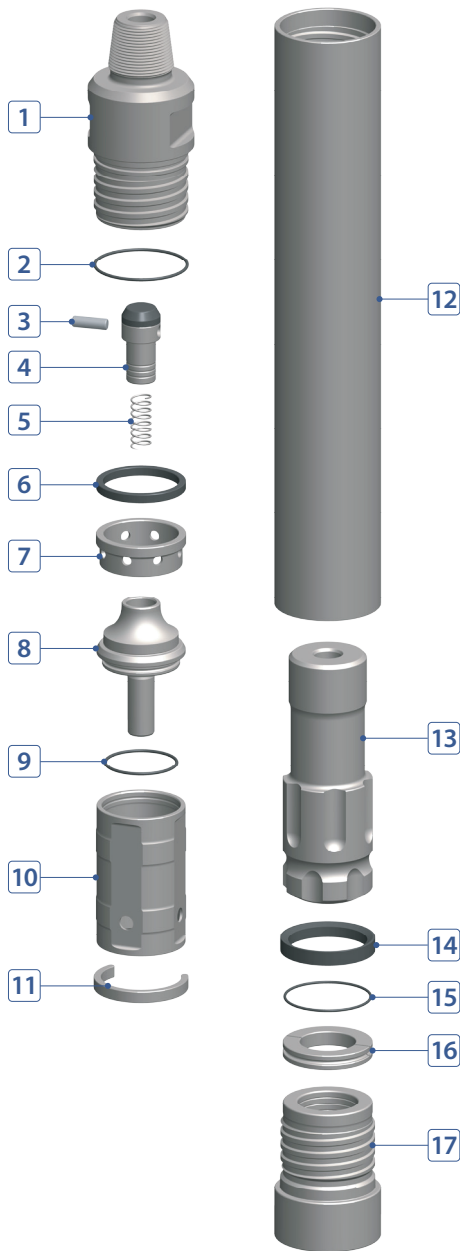

COMPONENT PART



No.	DESCRIPTION	Q'TY	PART #
1	Back Head	1	W080-02-A01DRP
2	Back Head O-Ring	1	W080-02-A03000
3	Plug (Choke)	1	W080-02-A08000
4	Air Check Valve	1	W080-02-A09000
5	Air Check Valve Spring	1	W080-02-A10000
6	Buffering	1	W080-02-A07000
7	Air Guide	1	W080-02-A11000
8	Air Distributor	1	W080-02-A15000
9	Air Distributor O-Ring	1	W080-02-A16000
10	Cylinder	1	W080-02-A17000
11	Cylinder Stop Ring (Steel)	1	W080-02-A43000
12	Wear Sleeve	1	W080-02-A25SDK
13	Piston	1	W080-02-A26SDK
14	Piston Stop Ring (Buffering)	1	W080-02-A28000
15	Bit Retainer O-Ring	1	W080-02-A37000
16	Bit Retainer	1	W080-02-A36SDK
17	Chuck	1	W080-02-A41SDK

HAMMER SPECIFICATIONS

Length (w/o drill bit)	48.91"	1,242.5 mm
Outside Diameter	7.08"	180 mm
Weight	390 lbs.	176.7 kg
Piston Weight	97.7 lbs.	44.3 kg
Hole Size	7-7/8" ~ 10"	200 ~ 254 mm
Connection	Std. 4-1/2" API Reg Pin	

AIR CONSUMPTION CHART

