

DTH HAMMER

WCS701 7" HAMMER WITH SD8 SHANK



[NO FOOT VALVE TYPE]

COMPONENT PART

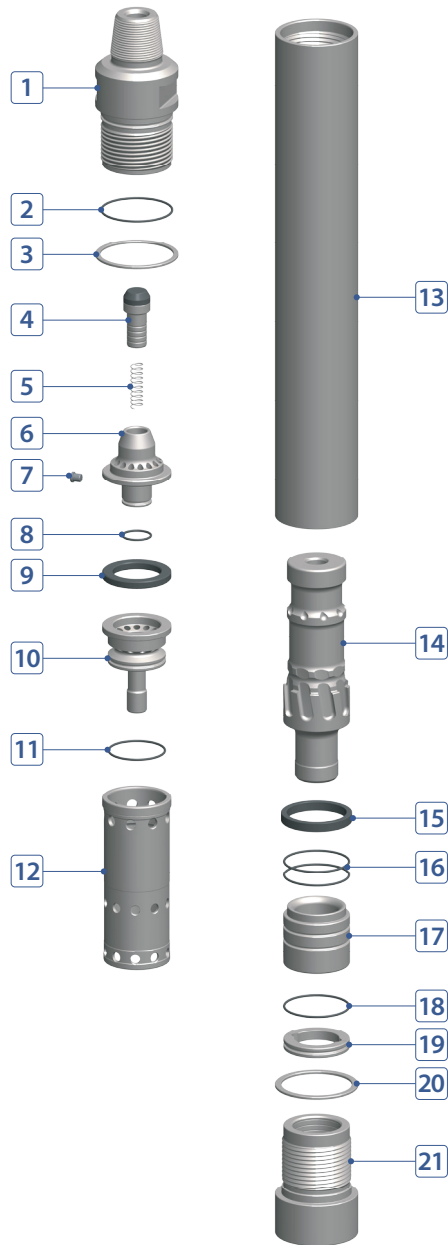

No.	DESCRIPTION	Q'TY	PART #
1	Back Head	1	T070-02-A01DRP
2	Back Head O-Ring	1	T070-02-A03000
3	Back Head Washer	1	T070-02-A02000
4	Air Check Valve	1	T070-02-A09000-01
5	Air Check Valve Spring	1	T070-02-A10000
6	Air Guide	1	T070-02-A11000
7	Air Guide Plug (Choke)	1	T070-02-A13000
8	Air Guide O-Ring	1	T070-02-A14000
9	Buffering	1	T070-02-A07000
10	Air Distributor	1	T070-02-A15000
11	Air Distributor O-Ring	1	T070-02-A16000
12	Cylinder	1	T070-02-A17000
13	Wear Sleeve	1	T070-02-A25000
14	Piston	1	T070-02-A26000
15	Piston Stop Ring	1	T070-02-A28000
16	Bearing O-Ring	2	T070-02-A32000
17	Bearing	1	T070-02-A31000
18	Bit Retainer O-Ring	1	T070-02-A37000
19	Bit Retainer	1	T070-02-A36000
20	Chuck Washer	1	T070-02-A39000
21	Chuck	1	T070-02-A41000

HAMMER SPECIFICATIONS

Length (w/o drill bit)	50.43"	1,281 mm
Outside Diameter	6.88"	175 mm
Weight	381.4 lbs.	173 kg
Piston Weight	77.2 lbs.	35 kg
Hole Size	6-1/16" ~ 8"	154 ~ 203 mm
Connection	Std. 4-1/2" API Reg Pin	

AIR CONSUMPTION CHART

