

DTH HAMMER

WCQ80 8" HAMMER WITH QL80 SHANK

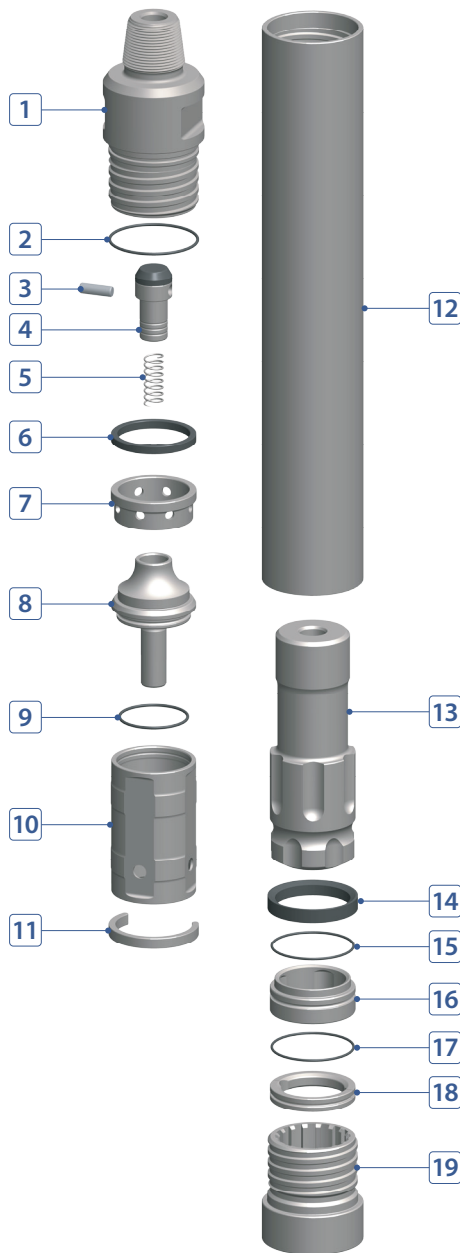

COMPONENT PART



No.	DESCRIPTION	Q'TY	PART #
1	Back Head	1	W080-02-A01CRP
2	Back Head O-Ring	1	W080-02-A03000
3	Plug (Choke)	1	W080-02-A08000
4	Air Check Valve	1	W080-02-A09000
5	Air Check Valve Spring	1	W080-02-A10000
6	Buffering	1	W080-02-A07000
7	Air Guide	1	W080-02-A11000
8	Air Distributor	1	W080-02-A15000
9	Air Distributor O-Ring	1	W080-02-A16000
10	Cylinder	1	W080-02-A17000
11	Cylinder Stop Ring (Steel)	1	W080-02-A43000
12	Wear Sleeve	1	W080-02-A25QLK
13	Piston	1	W080-02-A26QLK
14	Piston Stop Ring (Buffering)	1	W080-02-A28000
15	Bearing O-Ring	1	W080-02-A32000
16	Bearing	1	W080-02-A31QLK
17	Bit Retainer O-Ring	1	W080-02-A37000
18	Bit Retainer	1	W080-02-A36QLK
19	Chuck	1	W080-02-A41QLK

HAMMER SPECIFICATIONS

Length (w/o drill bit)	49.27"	1,251.5 mm
Outside Diameter	7.08"	180 mm
Weight	370.6 lbs.	168 kg
Piston Weight	95 lbs.	43 kg
Hole Size	7-7/8" ~ 10"	200 ~ 254 mm
Connection	Std. 4-1/2" API Reg Pin	

AIR CONSUMPTION CHART

