

# DTH HAMMER

## KSS80 8" HAMMER WITH SD8 SHANK

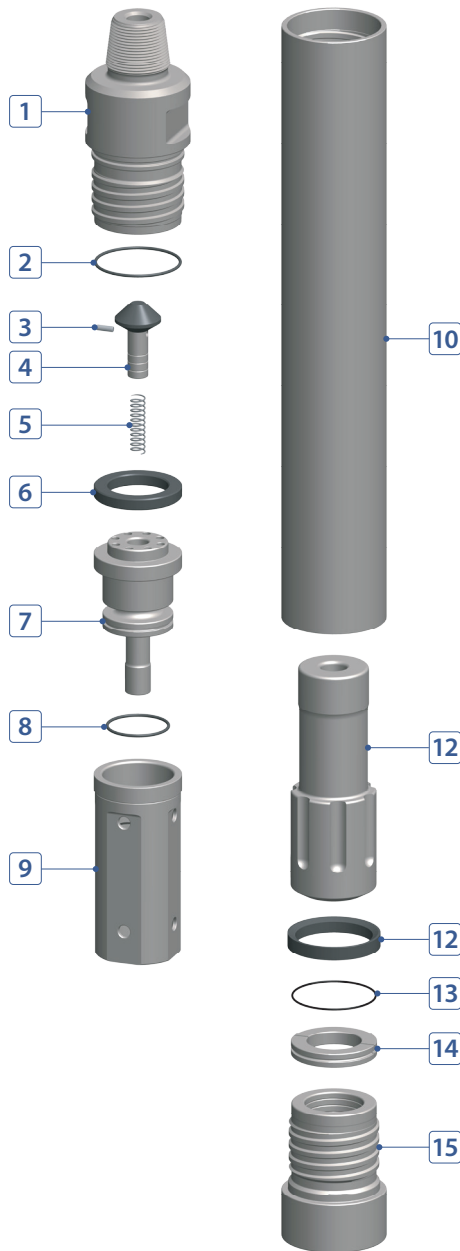

### COMPONENT PART



No.	DESCRIPTION	Q'TY	PART #
1	Back Head	1	K080-02-A01DRP
2	Back Head O-Ring	1	K080-02-A03000
3	Plug (Choke)	1	K080-02-A08000
4	Air Check Valve	1	K080-02-A09000
5	Air Check Valve Spring	1	K080-02-A10000
6	Buffering	1	K080-02-A07000
7	Air Distributor	1	K080-02-A15000
8	Air Distributor O-Ring	1	K080-02-A16000
9	Cylinder	1	K080-02-A17000
10	Wear Sleeve	1	K080-02-A25SDK
11	Piston	1	K080-02-A26SDK
12	Piston Stop Ring (Buffering)	1	K080-02-A28SIK
13	Bit Retainer O-Ring	1	K080-02-A37000
14	Bit Retainer	1	K080-02-A36SDK
15	Chuck (Drive Sub)	1	K080-02-A41SDK

### HAMMER SPECIFICATIONS

Length (w/o drill bit)	51.08"	1,297.6 mm
Outside Diameter	7.12"	181 mm
Weight	428 lbs.	194.2 kg
Piston Weight	84.9 lbs.	38.5 kg
Hole Size	7-7/8" ~ 10"	200 ~ 254 mm
Connection	Std. 4-1/2" API Reg Pin	

### AIR CONSUMPTION CHART

