

DTH HAMMER

KSQ80 8" HAMMER WITH QL80 SHANK

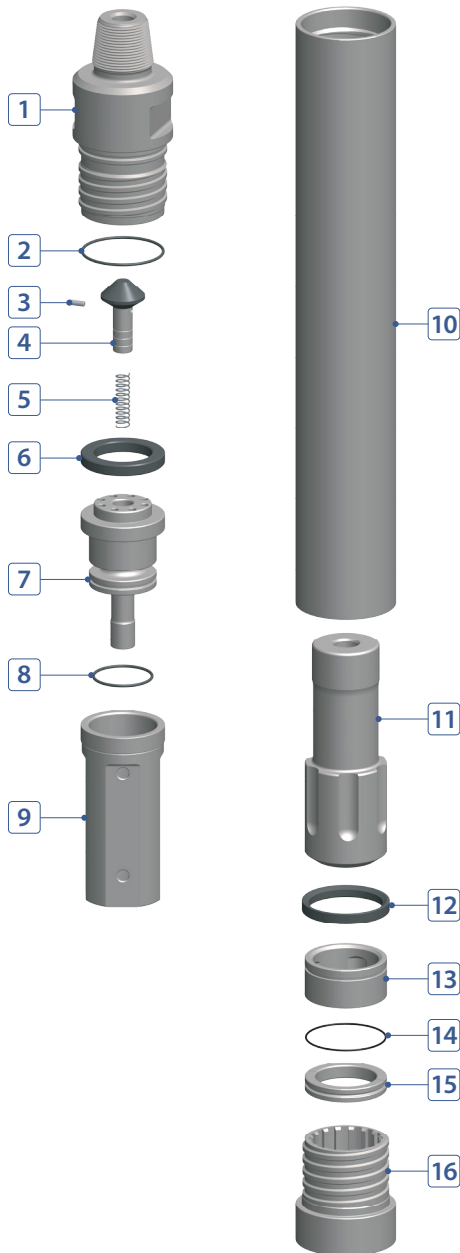

COMPONENT PART



No.	DESCRIPTION	Q'TY	PART #
1	Back Head	1	K080-02-A01DRP
2	Back Head O-Ring	1	K080-02-A03000
3	Plug (Choke)	1	K080-02-A08000
4	Air Check Valve	1	K080-02-A09000
5	Air Check Valve Spring	1	K080-02-A10000
6	Buffering	1	K080-02-A07000
7	Air Distributor	1	K080-02-A15000
8	Air Distributor O-Ring	1	K080-02-A16000
9	Cylinder	1	K080-02-A17000
10	Wear Sleeve	1	K080-02-A25QLK
11	Piston	1	K080-02-A26QLK
12	Piston Stop Ring (Buffering)	1	K080-02-A28QLK
13	Bearing	1	K080-02-A31QLK
14	Bit Retainer O-Ring	1	K080-02-A37000
15	Bit Retainer	1	K080-02-A36QLK
16	Chuck	1	K080-02-A41QLK

HAMMER SPECIFICATIONS

Length (w/o drill bit)	51.44"	1,306.6 mm
Outside Diameter	7.12"	181 mm
Weight	417.8 lbs.	189.5 kg
Piston Weight	83.8 lbs.	38 kg
Hole Size	7-7/8" ~ 10"	200 ~ 254 mm
Connection	Std. 4-1/2" API Reg Pin	

AIR CONSUMPTION CHART

