

DTH HAMMER

WCM651 6" HAMMER WITH MISSON60 SHANK



[NO FOOT VALVE TYPE]

COMPONENT PART

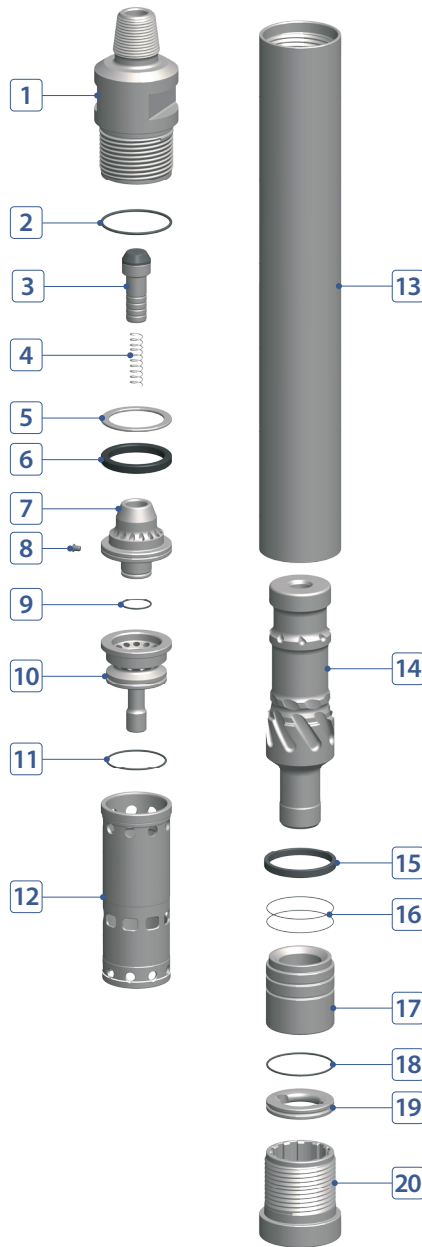

No.	DESCRIPTION	Q'TY	PART #
1	Back Head	1	T060-02-A01CRP
2	Back Head O-Ring	1	T060-02-A03000
3	Air Check Valve	1	T060-02-A09000-01
4	Air Check Valve Spring	1	T060-02-A10000
5	Buffering Washer	1	T060-02-A05000
6	Buffering	1	T060-02-A07000
7	Air Guide	1	T060-02-A11000
8	Air Guide Plug	1	T060-02-A13000
9	Air Guide O-Ring	1	T060-02-A14000
10	Air Distributor	1	T060-02-A15000
11	Air Distributor O-Ring	1	T060-02-A16000
12	Cylinder	1	T060-02-A17000
13	Wear Sleeve	1	T060-02-A25MSN
14	Piston	1	T060-02-A26MSN-01
15	Piston Stop Ring	1	T060-02-A28000
16	Bearing O-Ring	2	T060-02-A32000
17	Bearing	1	T060-02-A31MSN-01
18	Bit Retainer O-Ring	1	T060-02-A37000
19	Bit Retainer	1	T060-02-A36MSN
20	Chuck	1	T060-02-A41MSN

HAMMER SPECIFICATIONS

Length (w/o drill bit)	43.44"	1,103.5 mm
Outside Diameter	5.82"	148 mm
Weight	220.5 lbs.	100 kg
Piston Weight	50.7 lbs.	23 kg
Hole Size	6-1/16" ~ 8"	154 ~ 203 mm
Connection	Std. 3-1/2" API Reg Pin	

AIR CONSUMPTION CHART

