

DTH HAMMER

WCI60 6" HAMMER WITH DHD360 SHANK

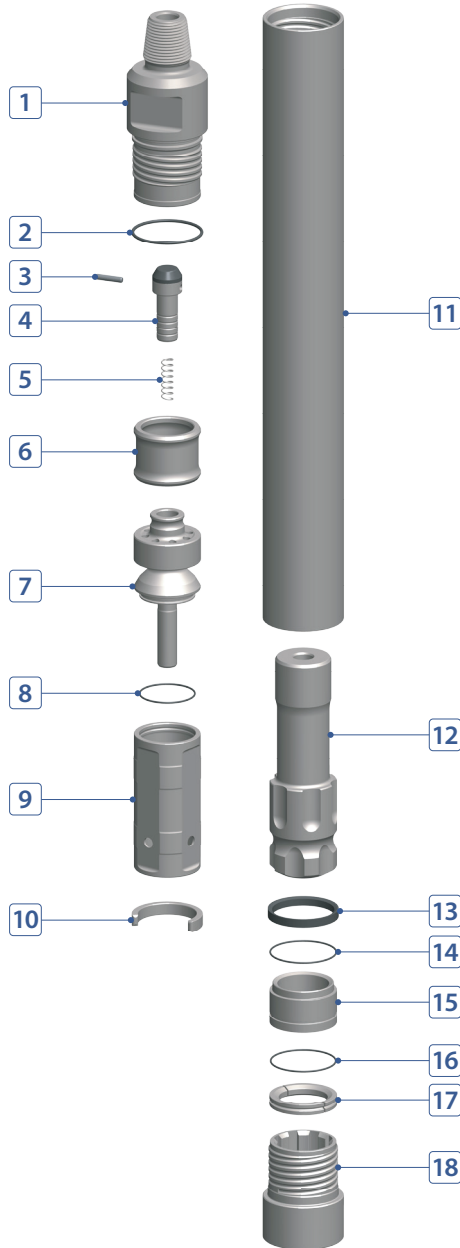

COMPONENT PART



No.	DESCRIPTION	Q'TY	PART #
1	Back Head	1	W060-02-A01CRP
2	Back Head O-Ring	1	W060-02-A03000
3	Plug (Choke)	1	W060-02-A08000
4	Air Check Valve	1	W060-02-A09000
5	Air Check Valve Spring	1	W060-02-A10000
6	Tube Guide	1	W060-02-A19000
7	Air Distributor	1	W060-02-A15000
8	Air Distributor O-Ring	1	W060-02-A16000
9	Cylinder	1	W060-02-A17000
10	Cylinder Stop Ring	1	W060-02-A43000
11	Wear Sleeve	1	W060-02-A25SIM
12	Piston	1	W060-02-A26DHD
13	Piston Stop Ring (Buffering)	1	W060-02-A28SIM
14	Bearing O-Ring	1	W060-02-A32000
15	Bearing	1	W060-02-A31DHD
16	Bit Retainer O-Ring	1	W060-02-A37000
17	Bit Retainer	1	W060-02-A36DHD
18	Chuck	1	W060-02-A41DHD

HAMMER SPECIFICATIONS

Length (w/o drill bit)	49.83"	1,265.8 mm
Outside Diameter	5.41"	137.5 mm
Weight	222.7 lbs.	101 kg
Piston Weight	44.5 lbs.	20.2 kg
Hole Size	6" ~ 8"	152 ~ 203 mm
Connection	Std. 3-1/2" API Reg Pin	

AIR CONSUMPTION CHART

