

# DTH HAMMER

## KSI60 6" HAMMER WITH DHD360 SHANK

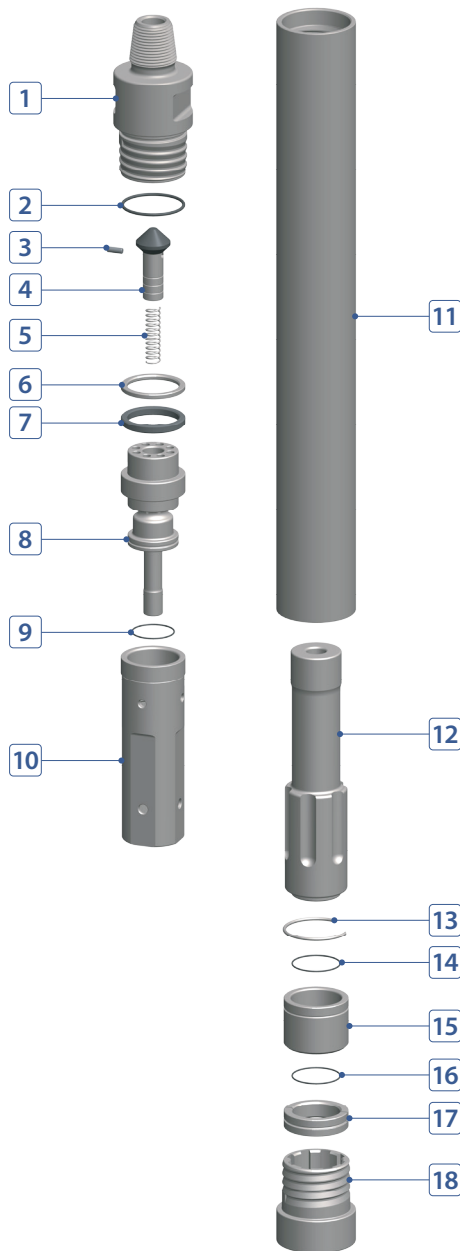

### COMPONENT PART



No.	DESCRIPTION	Q'TY	PART #
1	Back Head	1	K060-02-A01CRP
2	Back Head O-Ring	1	K060-02-A03000
3	Plug (Choke)	1	K060-02-A08000
4	Air Check Valve	1	K060-02-A09000
5	Air Check Valve Spring	1	K060-02-A10000
6	Buffering Washer (Steel)	1	K060-02-A05000
7	Buffering	1	K060-02-A07000
8	Air Distributor	1	K060-02-A15000
9	Air Distributor O-Ring	1	K060-02-A16000
10	Cylinder	1	K060-02-A17000
11	Wear Sleeve	1	K060-02-A25000
12	Piston	1	K060-02-A26DHD
13	Piston Stop Ring (Key)	1	K060-02-A29000
14	Bearing O-Ring	1	K060-02-A32000
15	Bearing	1	K060-02-A31DHD
16	Bit Retainer O-Ring	1	K060-02-A37000
17	Bit Retainer	1	K060-02-A36DHD
18	Chuck (Drive Sub)	1	K060-02-A41DHD

### HAMMER SPECIFICATIONS

Length (w/o drill bit)	48.7"	1,237 mm
Outside Diameter	5.41"	137.5 mm
Weight	226.7 lbs.	102.8 kg
Piston Weight	46 lbs.	20.8 kg
Hole Size	6" ~ 8"	152 ~ 203 mm
Connection	Std. 3-1/2" API Reg Pin	

### AIR CONSUMPTION CHART

