

COMPONENT PART

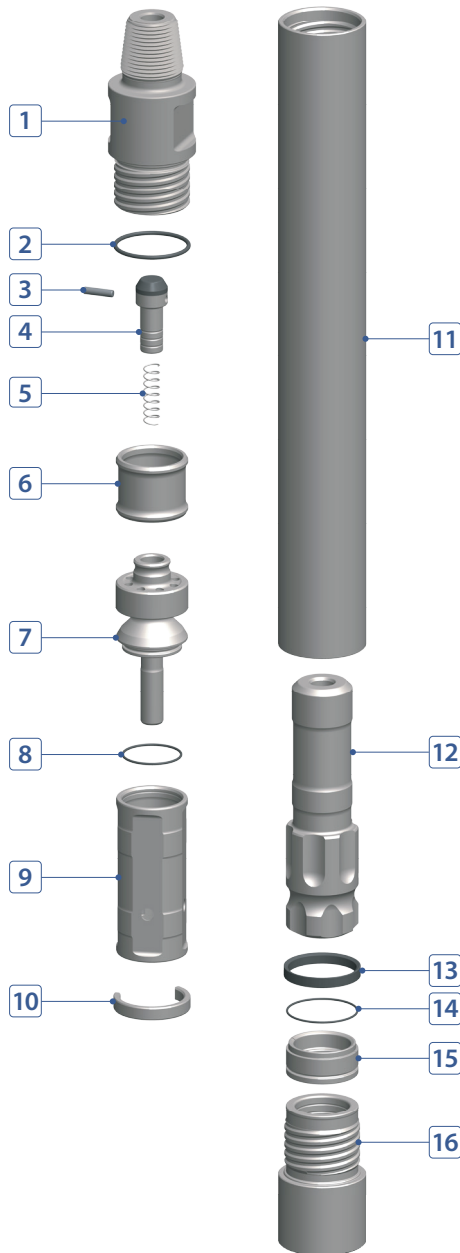

No.	DESCRIPTION	Q'TY	PART #
1	Back Head	1	W050-02-A01CRP
2	Back Head O-Ring	1	W050-02-A03000
3	Plug (Choke)	1	W050-02-A08000
4	Air Check Valve	1	W050-02-A09000
5	Air Check Valve Spring	1	W050-02-A10000
6	Tube Buffering	1	W050-02-A21000
7	Air Distributor	1	W050-02-A15000
8	Air Distributor O-Ring	1	W050-02-A16000
9	Cylinder	1	W050-02-A17000
10	Cylinder Stop Ring	1	W050-02-A43000
11	Wear Sleeve	1	W050-02-A25000
12	Piston	1	W050-02-A26SDK
13	Piston Stop Ring (Buffering)	1	W050-02-A28000
14	Bit Retainer O-Ring	1	W050-02-A37000
15	Bit Retainer	1	W050-02-A36SDK
16	Chuck	1	W050-02-A41SDK

HAMMER SPECIFICATIONS

Length (w/o drill bit)	41.55"	1,055.5 mm
Outside Diameter	4.52"	115 mm
Weight	133 lbs.	60.3 kg
Piston Weight	27.3 lbs.	12.4 kg
Hole Size	5" ~ 6"	127 ~ 152 mm
Connection	Std. 3-1/2" API Reg Pin	

AIR CONSUMPTION CHART

