

DTH HAMMER

WCQ551 5.5" HAMMER WITH QL50 SHANK



[NO FOOT VALVE TYPE]

COMPONENT PART

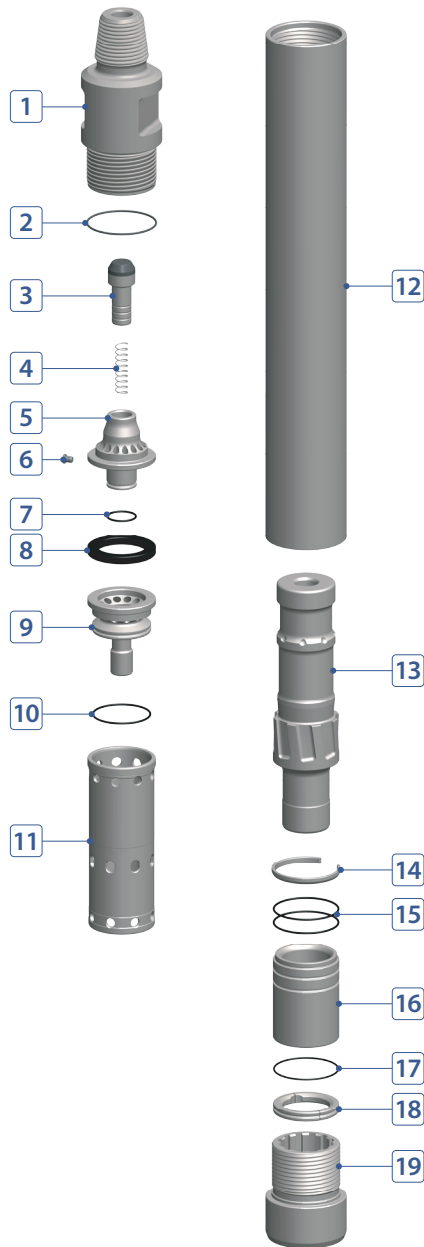

No.	DESCRIPTION	Q'TY	PART #
1	Back Head	1	T055-02-A01CRP
2	Back Head O-Ring	1	T055-02-A03000
3	Air Check Valve	1	T055-02-A09000
4	Air Check Valve Spring	1	T055-02-A10000
5	Air Guide	1	T055-02-A11000
6	Air Guide Plug (Choke)	1	T055-02-A13000
7	Air Guide O-Ring	1	T055-02-A14000
8	Buffering	1	T055-02-A07000
9	Air Distributor	1	T055-02-A15000
10	Air Distributor O-Ring	1	T055-02-A16000
11	Cylinder	1	T055-02-A17000
12	Wear Sleeve	1	T055-02-A25000
13	Piston	1	T055-02-A261QK
14	Piston Stop Ring (Steel)	1	T055-02-A29000
15	Bearing O-Ring	2	T055-02-A32000
16	Bearing	1	T055-02-A31QLK
17	Bit Retainer O-Ring	1	T055-02-A37000
18	Bit Retainer	1	T055-02-A36QLK
19	Chuck	1	T055-02-A41QLK

HAMMER SPECIFICATIONS

Length (w/o drill bit)	39.17"	995 mm
Outside Diameter	4.88"	124 mm
Weight	148 lbs.	67.1 kg
Piston Weight	32.4 lbs.	14.7 kg
Hole Size	5.12" ~ 6"	130 ~ 152 mm
Connection	Std. 3-1/2" API Reg Pin	

AIR CONSUMPTION CHART

