

DTH HAMMER

WCQ50 5" HAMMER WITH QL50 SHANK

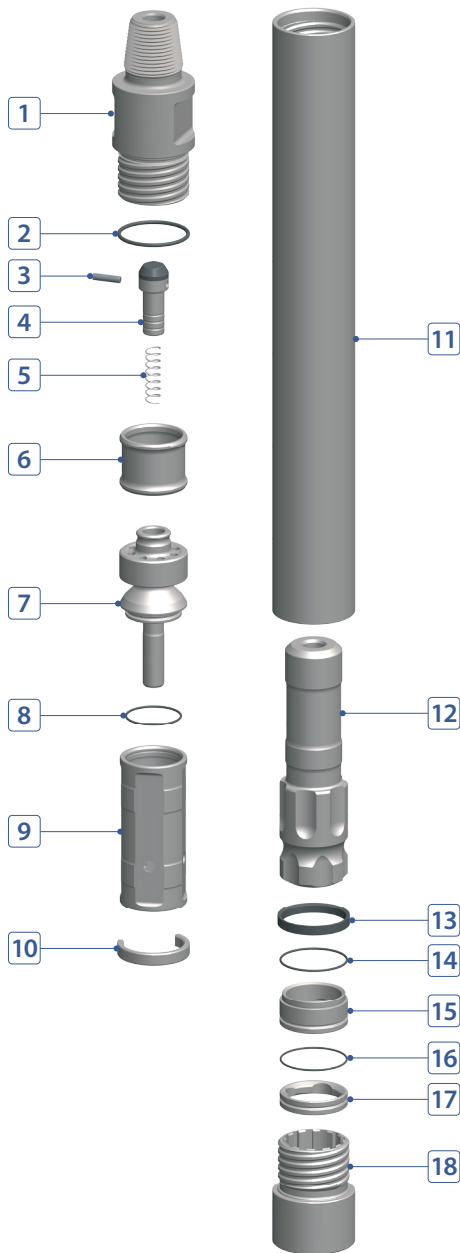

COMPONENT PART



No.	DESCRIPTION	Q'TY	PART #
1	Back Head	1	W050-02-A01CRP
2	Back Head O-Ring	1	W050-02-A03000
3	Plug (Choke)	1	W050-02-A08000
4	Air Check Valve	1	W050-02-A09000
5	Air Check Valve Spring	1	W050-02-A10000
6	Tube Buffering	1	W050-02-A21000
7	Air Distributor	1	W050-02-A15000
8	Air Distributor O-Ring	1	W050-02-A16000
9	Cylinder	1	W050-02-A17000
10	Cylinder Stop Ring	1	W050-02-A43000
11	Wear Sleeve	1	W050-02-A25000
12	Piston	1	W050-02-A26QLK
13	Piston Stop Ring (Buffering)	1	W050-02-A28000
14	Bearing O-Ring	1	W050-02-A32000
15	Bearing	1	W050-02-A31QLK
16	Bit Retainer O-Ring	1	W050-02-A37000
17	Bit Retainer	1	W050-02-A36QLK
18	Chuck	1	W050-02-A41QLK

HAMMER SPECIFICATIONS

Length (w/o drill bit)	40.76"	1,035.5 mm
Outside Diameter	4.52"	115 mm
Weight	128.8 lbs.	58.4 kg
Piston Weight	26.9 lbs.	12.2 kg
Hole Size	5" ~ 6"	127 ~ 152 mm
Connection	Std. 3-1/2" API Reg Pin	

AIR CONSUMPTION CHART

