

# DTH HAMMER

## WCM501 5" HAMMER WITH MISSION45 SHANK



[NO FOOT VALVE TYPE]

### COMPONENT PART

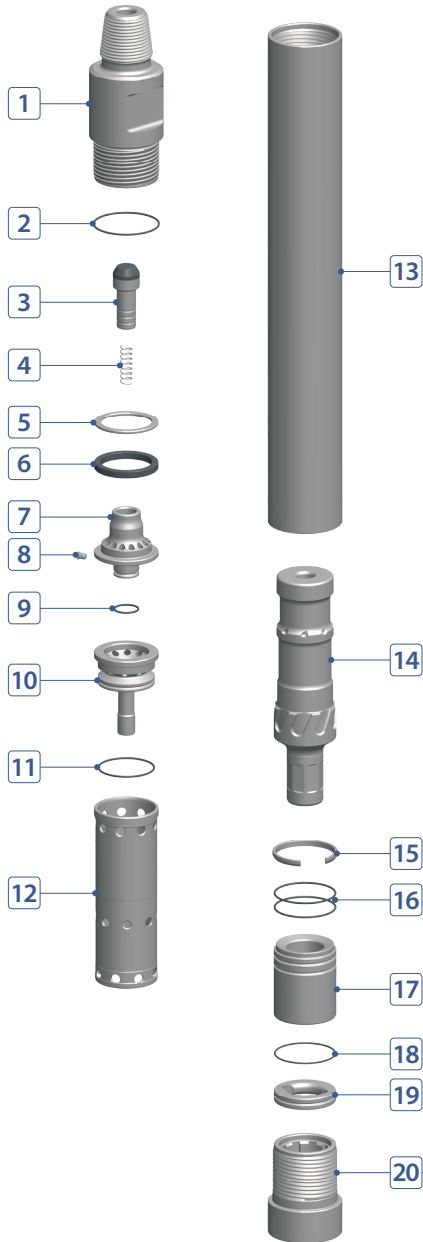

No.	DESCRIPTION	Q'TY	PART #
1	Back Head	1	T050-02-A01ARP
2	Back Head O-Ring	1	T050-02-A03000
3	Air Check Valve	1	T050-02-A09000
4	Air Check Valve Spring	1	T050-02-A10000
5	Buffering Washer (Steel)	1	T050-02-A05000
6	Buffering	1	T050-02-A07000
7	Air Guide	1	T050-02-A11000
8	Air Guide Plug (Choke)	1	T050-02-A13000
9	Air Guide O-Ring	1	T050-02-A14000
10	Air Distributor	1	T050-02-A15000
11	Air Distributor O-Ring	1	T050-02-A16000
12	Cylinder	1	T050-02-A17000
13	Wear Sleeve	1	T050-02-A25000
14	Piston	1	T050-02-A26000
15	Piston Stop Ring (Steel)	1	T050-02-A29000
16	Bearing O-Ring	2	T050-02-A32000
17	Bearing	1	T050-02-A31000
18	Bit Retainer O-Ring	1	T050-02-A37000
19	Bit Retainer	1	T050-02-A36000
20	Chuck	1	T050-02-A41000

### HAMMER SPECIFICATIONS

Length (w/o drill bit)	38.25"	971.8 mm
Outside Diameter	4.56"	116 mm
Weight	127.9 lbs.	58 kg
Piston Weight	28.7 lbs.	13 kg
Hole Size	5.12" ~ 6"	130 ~ 152 mm
Connection	Std. 3-1/2" API Reg Pin	

### AIR CONSUMPTION CHART

