

DTH HAMMER

KSS50 5" HAMMER WITH SD5 SHANK

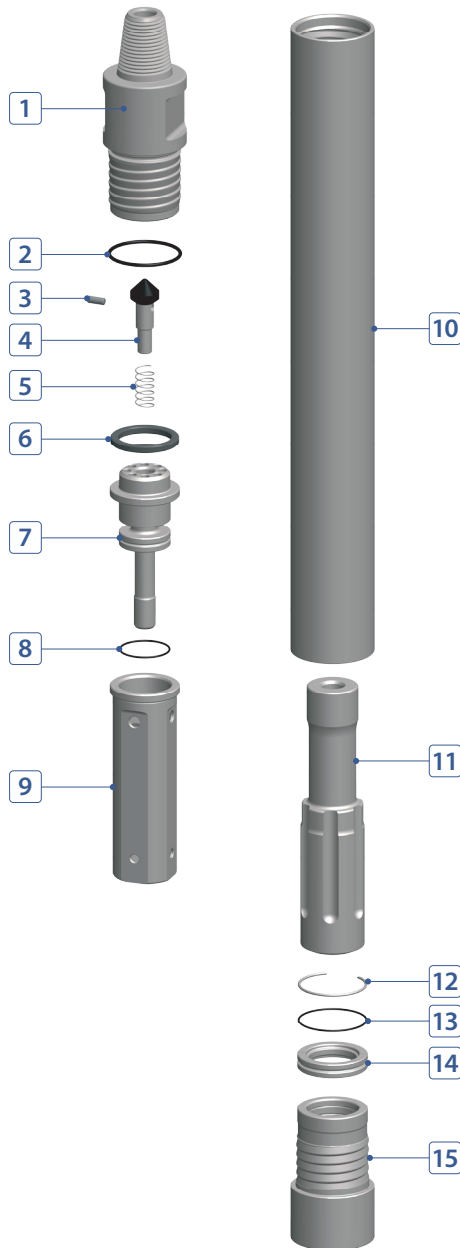

COMPONENT PART



No.	DESCRIPTION	Q'TY	PART #
1	Back Head	1	K050-02-A01CRP
2	Back Head O-Ring	1	K050-02-A03000
3	Plug (Choke)	1	K050-02-A08000
4	Air Check Valve	1	K050-02-A09000
5	Air Check Valve Spring	1	K050-02-A10000
6	Buffering	1	K050-02-A07000
7	Air Distributor	1	K050-02-A15000
8	Air Distributor O-Ring	1	K050-02-A16000
9	Cylinder	1	K050-02-A17000
10	Wear Sleeve	1	K050-02-A25000
11	Piston	1	K050-02-A26SDK
12	Piston Stop Ring (Key)	1	K050-02-A29000
13	Bit Retainer O-Ring	1	K050-02-A37000
14	Bit Retainer	1	K050-02-A36SDK
15	Chuck (Drive Sub)	1	K050-02-A41SDK

HAMMER SPECIFICATIONS

Length (w/o drill bit)	42.48"	1,079 mm
Outside Diameter	4.52"	115 mm
Weight	142.2 lbs.	64.5 kg
Piston Weight	26.5 lbs.	12 kg
Hole Size	5" ~ 6"	127 ~ 152 mm
Connection	Std. 3-1/2" API Reg Pin	

AIR CONSUMPTION CHART

