

# DTH HAMMER

## WCM401 4" HAMMER WITH MISSION40 SHANK



[NO FOOT VALVE TYPE]

### COMPONENT PART

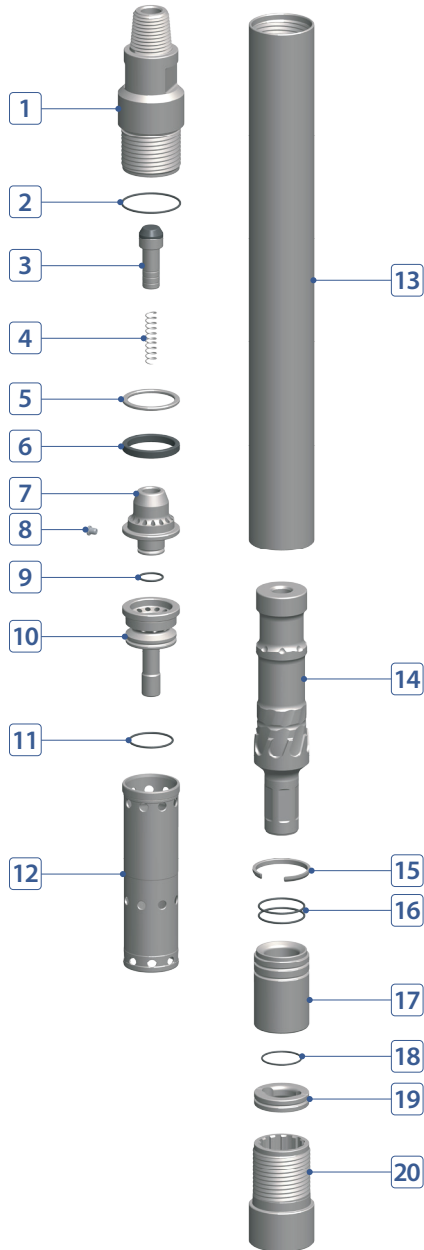

| No. | DESCRIPTION              | Q'TY | PART #         |
|-----|--------------------------|------|----------------|
| 1   | Back Head                | 1    | T040-02-A01ARP |
| 2   | Back Head O-Ring         | 1    | T040-02-A03000 |
| 3   | Air Check Valve          | 1    | T040-02-A09000 |
| 4   | Air Check Valve Spring   | 1    | T040-02-A10000 |
| 5   | Buffering Washer (Steel) | 1    | T040-02-A05000 |
| 6   | Buffering                | 1    | T040-02-A07000 |
| 7   | Air Guide                | 1    | T040-02-A11000 |
| 8   | Air Guide Plug (Choke)   | 1    | T040-02-A13000 |
| 9   | Air Guide O-Ring         | 1    | T040-02-A14000 |
| 10  | Air Distributor          | 1    | T040-02-A15000 |
| 11  | Air Distributor O-Ring   | 1    | T040-02-A16000 |
| 12  | Cylinder                 | 1    | T040-02-A17000 |
| 13  | Wear Sleeve              | 1    | T040-02-A25000 |
| 14  | Piston                   | 1    | T040-02-A26000 |
| 15  | Piston Stop Ring (Steel) | 1    | T040-02-A29000 |
| 16  | Bearing O-Ring           | 2    | T040-02-A32000 |
| 17  | Bearing                  | 1    | T040-02-A31MSN |
| 18  | Bit Retainer O-Ring      | 1    | T040-02-A37000 |
| 19  | Bit Retainer             | 1    | T040-02-A36MSN |
| 20  | Chuck                    | 1    | T040-02-A41MSN |

### HAMMER SPECIFICATIONS

|                        |                         |              |
|------------------------|-------------------------|--------------|
| Length (w/o drill bit) | 36.81"                  | 935.2 mm     |
| Outside Diameter       | 3.85"                   | 98 mm        |
| Weight                 | 80.3 lbs.               | 36.4 kg      |
| Piston Weight          | 19.4 lbs.               | 8.8 kg       |
| Hole Size              | 4" ~ 5-1/8"             | 102 ~ 130 mm |
| Connection             | Std. 2-3/8" API Reg Pin |              |

### AIR CONSUMPTION CHART

