

# DTH HAMMER

## WCI40 4" HAMMER WITH DHD340 SHANK

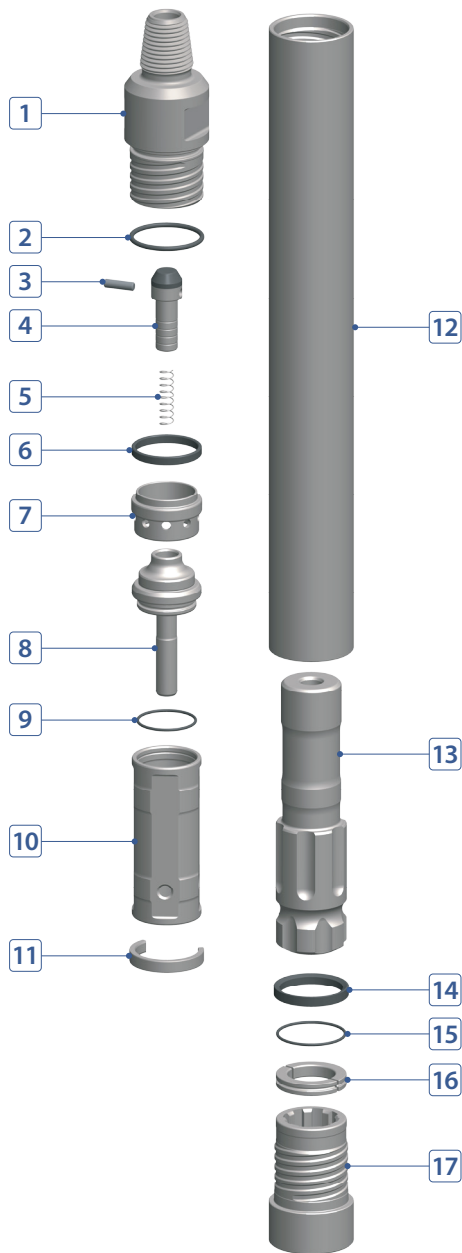

### COMPONENT PART



No.	DESCRIPTION	Q'TY	PART #
1	Back Head	1	W040-02-A01ARP
2	Back Head O-Ring	1	W040-02-A03000
3	Plug (Choke)	1	W040-02-A08000
4	Air Check Valve	1	W040-02-A09000
5	Air Check Valve Spring	1	W040-02-A10000
6	Buffering	1	W040-02-A07000
7	Air Guide	1	W040-02-A11000
8	Air Distributor	1	W040-02-A15SIQ
9	Air Distributor O-Ring	1	W040-02-A16000
10	Cylinder	1	W040-02-A17000
11	Cylinder Stop Ring	1	W040-02-A43000
12	Wear Sleeve	1	W040-02-A25000
13	Piston	1	W040-02-A26DHD
14	Piston Stop Ring (Buffering)	1	W040-02-A28000
15	Bit Retainer O-Ring	1	W040-02-A37000
16	Bit Retainer	1	W040-02-A36DHD
17	Chuck	1	W040-02-A41DHD

### HAMMER SPECIFICATIONS

Length (w/o drill bit)	34.88"	886.2 mm
Outside Diameter	3.85"	98 mm
Weight	79.4 lbs.	36 kg
Piston Weight	20.5 lbs.	9.3 kg
Hole Size	4-1/8" ~ 5-1/8"	105 ~ 130 mm
Connection	Std. 2-3/8" API Reg Pin	

### AIR CONSUMPTION CHART

