

DTH HAMMER

KSI40 4" HAMMER WITH DHD340 SHANK

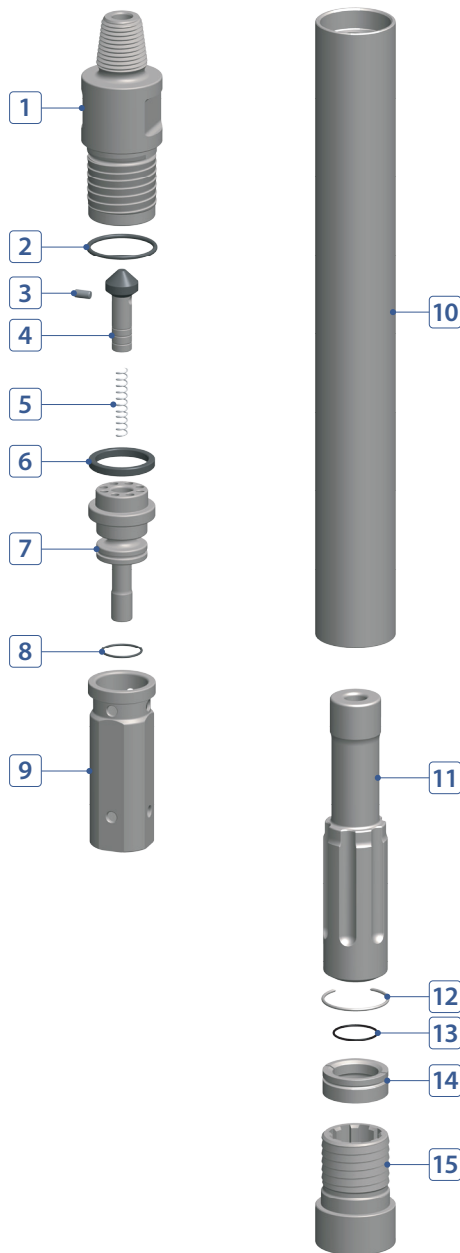

COMPONENT PART



No.	DESCRIPTION	Q'TY	PART #
1	Back Head	1	K040-02-A01ARP
2	Back Head O-Ring	1	K040-02-A03000
3	Plug (Choke)	1	K040-02-A08000
4	Air Check Valve	1	K040-02-A09000
5	Air Check Valve Spring	1	K040-02-A10000
6	Buffering	1	K040-02-A07000
7	Air Distributor	1	K040-02-A15000
8	Air Distributor O-Ring	1	K040-02-A16000
9	Cylinder	1	K040-02-A17000
10	Wear Sleeve	1	K040-02-A25000
11	Piston	1	K040-02-A26DHD
12	Piston Stop Ring (Key)	1	K040-02-A29000
13	Bit Retainer O-Ring	1	K040-02-A37000
14	Bit Retainer	1	K040-02-A36DHD
15	Chuck (Drive Sub)	1	K040-02-A41DHD

HAMMER SPECIFICATIONS

Length (w/o drill bit)	36.22"	920 mm
Outside Diameter	3.81"	97 mm
Weight	85.3 lbs.	38.7 kg
Piston Weight	19 lbs.	8.6 kg
Hole Size	4-1/8" ~ 5-1/8"	105 ~ 130 mm
Connection	Std. 2-3/8" API Reg Pin	

AIR CONSUMPTION CHART

