

COMPONENT PART

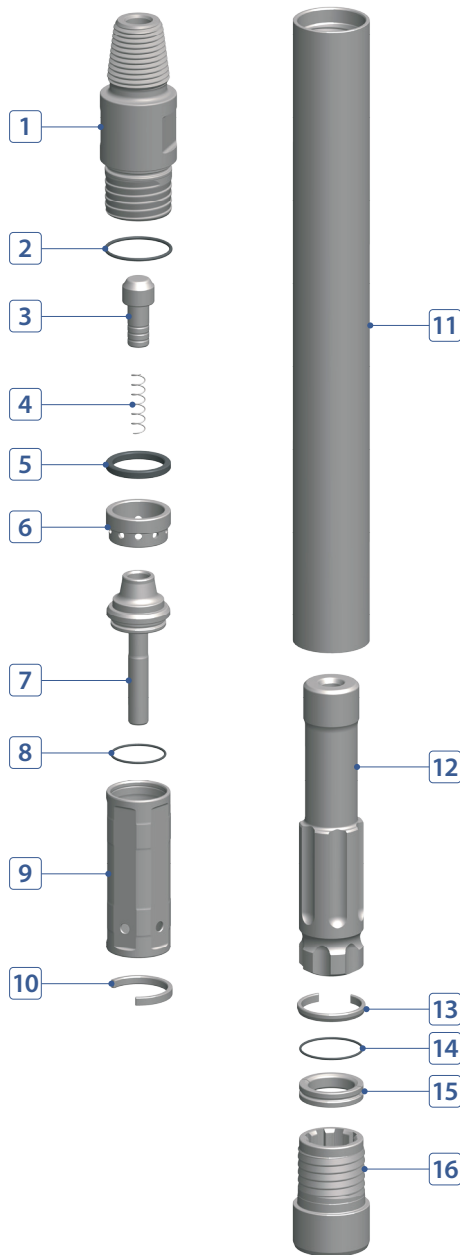

No.	DESCRIPTION	Q'TY	PART #
1	Back Head	1	W030-02-A01ARP
2	Back Head O-Ring	1	W030-02-A03000
3	Air Check Valve	1	W030-02-A09000
4	Air Check Valve Spring	1	W030-02-A10000
5	Buffering	1	W030-02-A07000
6	Air Guide	1	W030-02-A11000
7	Air Distributor	1	W030-02-A15000
8	Air Distributor O-Ring	1	W030-02-A16000
9	Cylinder	1	W030-02-A17000
10	Cylinder Stop Ring	1	W030-02-A43000
11	Wear Sleeve	1	W030-02-A25MCH
12	Piston	1	W030-02-A26MCH
13	Piston Stop Ring (Steel)	1	W030-02-A29000
14	Bit Retainer O-Ring	1	W030-02-A37000
15	Bit Retainer	1	W030-02-A36MCH
16	Chuck	1	W030-02-A41MCH

HAMMER SPECIFICATIONS

Length (w/o drill bit)	30.19"	767 mm
Outside Diameter	2.99"	76 mm
Weight	41.8 lbs.	19 kg
Piston Weight	11.3 lbs.	5.1 kg
Hole Size	3-3/8" ~ 5"	86 ~ 127 mm
Connection	Std. 2-3/8" API Reg Pin	

AIR CONSUMPTION CHART

