

DTH HAMMER

WCC301 3" HAMMER WITH COP32 SHANK

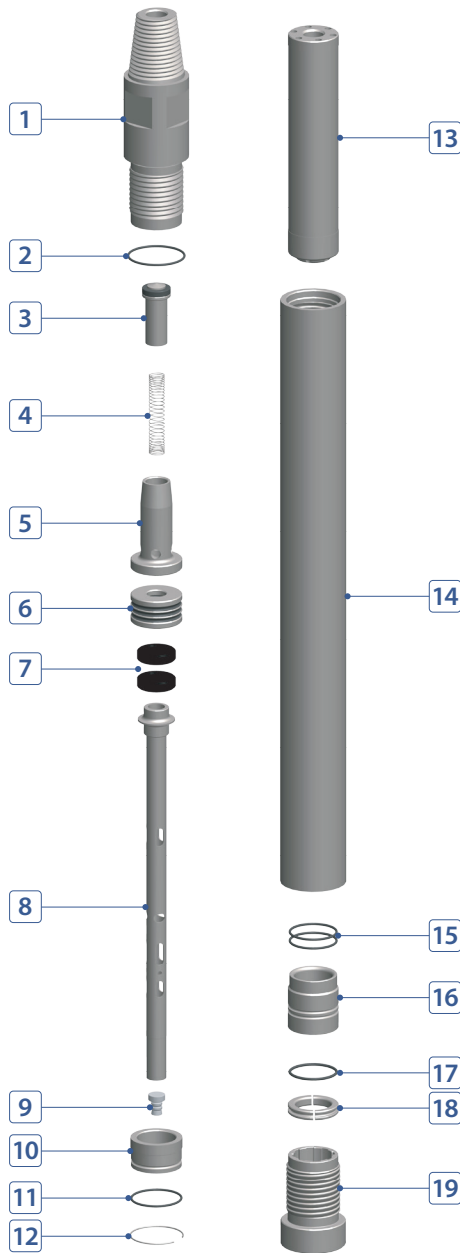

COMPONENT PART



No.	DESCRIPTION	Q'TY	PART #
1	Back Head	1	W030-01-A01ARP
2	Back Head O-Ring	1	W030-01-A03000
3	Air Check Valve	1	W030-01-A09000
4	Air Check Valve Spring	1	W030-01-A10000
5	Valve Body	1	W030-01-A11000
6	Compression Ring	1	W030-01-A06000
7	Buffering	2	W030-01-A07000
8	Control Tube	1	W030-01-A23000
9	Choke Plug	1	W030-01-A55000
10	Cover	1	W030-01-A18000
11	O-Ring	1	W030-01-A52000
12	Lock Ring	1	W030-01-A27000
13	Piston	1	W030-01-A26000
14	Cylinder (Wear Sleeve)	1	W030-01-A24000
15	O-Ring	2	W030-01-A52000
16	Bushing	1	W030-01-A30000
17	O-Ring	1	W030-01-A52000
18	Stop Ring Pair	1	W030-01-A35000
19	Chuck	1	W030-01-A41000

HAMMER SPECIFICATIONS

Length (w/o drill bit)	33.87"	860.35 mm
Outside Diameter	3"	77.5 mm
Weight	52.2 lbs.	23.7 kg
Piston Weight	8.6 lbs.	4 kg
Hole Size	3.46" ~ 4.13"	88 ~ 105mm
Connection	Std. 2-3/8" API Reg Pin	

AIR CONSUMPTION CHART

