

DTH HAMMER

WCM20 2" HAMMER WITH MACH20 SHANK

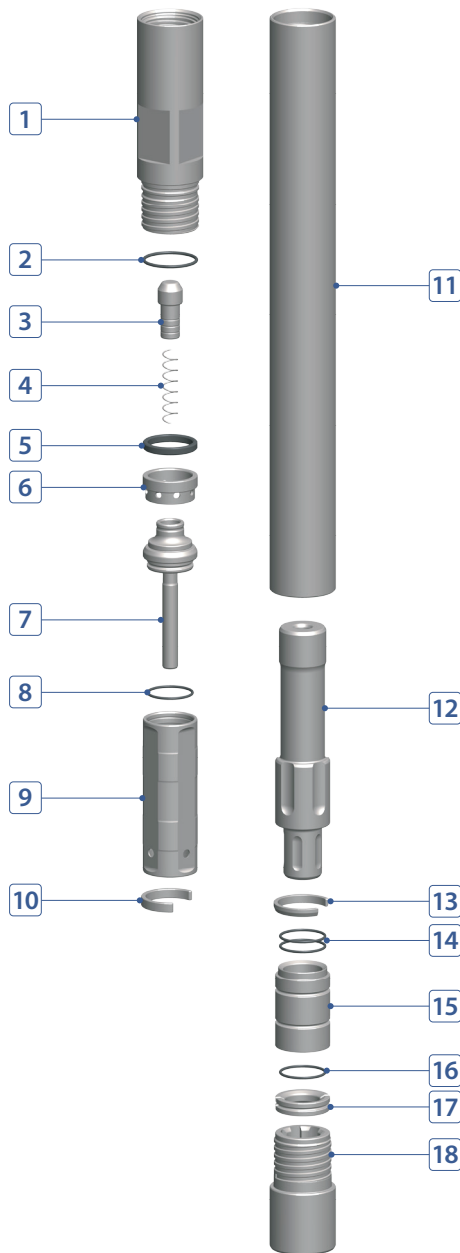

COMPONENT PART



No.	DESCRIPTION	Q'TY	PART #
1	Back Head	1	W020-02-A015DB
2	Back Head O-Ring	1	W020-02-A03000
3	Air Check Valve	1	W020-02-A09000
4	Air Check Valve Spring	1	W020-02-A10000
5	Buffering	1	W020-02-A07000
6	Air Guide	1	W020-02-A11000
7	Air Distributor	1	W020-02-A15000
8	Air Distributor O-Ring	1	W020-02-A16000
9	Cylinder	1	W020-02-A17000
10	Cylinder Stop Ring	1	W020-02-A43000
11	Wear Sleeve	1	W020-02-A25000
12	Piston	1	W020-02-A26000
13	Piston Stop Ring (Steel)	1	W020-02-A29000
14	Bearing O-Ring	2	W020-02-A32000
15	Bearing	1	W020-02-A31000
16	Bit Retainer O-Ring	1	W020-02-A37000
17	Bit Retainer	1	W020-02-A36000
18	Chuck	1	W020-02-A41000

HAMMER SPECIFICATIONS

Length (w/o drill bit)	29.48"	749 mm
Outside Diameter	2.36"	60 mm
Weight	24.3 lbs.	11 kg
Piston Weight	5.1 lbs.	2.3 kg
Hole Size	2.75" ~ 3.14"	70 ~ 80 mm
Connection	Std. 50mm DIN 405 6TPI BOX	

AIR CONSUMPTION CHART

