

DTH HAMMER

WT121 12" HAMMER WITH NUMA120 SHANK



[NO FOOT VALVE TYPE]

COMPONENT PART

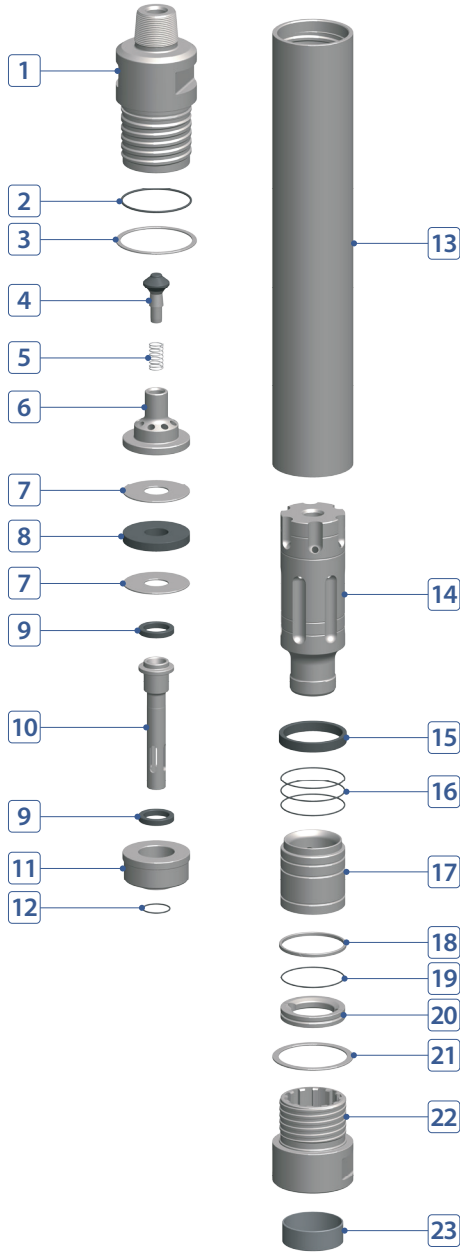

No.	DESCRIPTION	Q'TY	PART #
1	Back Head	1	T120-01-A01FRP
2	Back Head O-Ring	1	T120-01-A03000
3	Breakout Washer (Back Head)	1	T120-01-A02000
4	Air Check Valve	1	T120-01-A09000
5	Air Check Valve Spring	1	T120-01-A10000
6	Air Guide	1	T120-01-A11000
7	Buffering Washer	2	T120-01-A05000
8	Buffering	1	T120-01-A07000
9	Tube Buffering	2	T120-01-A21000
10	Feed Tube	1	T120-01-A23000
11	Tube Guide	1	T120-01-A19000
12	Tube Guide O-Ring	1	T120-01-A20000
13	Wear Sleeve	1	T120-01-A25000
14	Piston	1	T120-01-A26000
15	Piston Stop Ring	1	T120-01-A28000
16	Bearing O-Ring	3	T120-01-A32000
17	Bearing	1	T120-01-A31000
18	Bearing Stop Ring	1	T120-01-A34000
19	Bit Retainer O-Ring	1	T120-01-A37000
20	Bit Retainer	1	T120-01-A36000
21	Breakout Washer (Chuck)	1	T120-01-A39000
22	Chuck	1	T120-01-A41000
23	Chuck Bushing	1	T120-01-A54000

HAMMER SPECIFICATIONS

Length (w/o drill bit)	73.18"	1,859 mm
Outside Diameter	10.62"	270 mm
Weight	1,345 lbs.	610 kg
Piston Weight	276.7 lbs.	125.5 kg
Hole Size	12" ~ 17-1/2"	304 ~ 445 mm
Connection	Std. 6-5/8" API Reg Pin	

AIR CONSUMPTION CHART

