

DTH HAMMER

WN122 12" HAMMER WITH NUMA120 SHANK

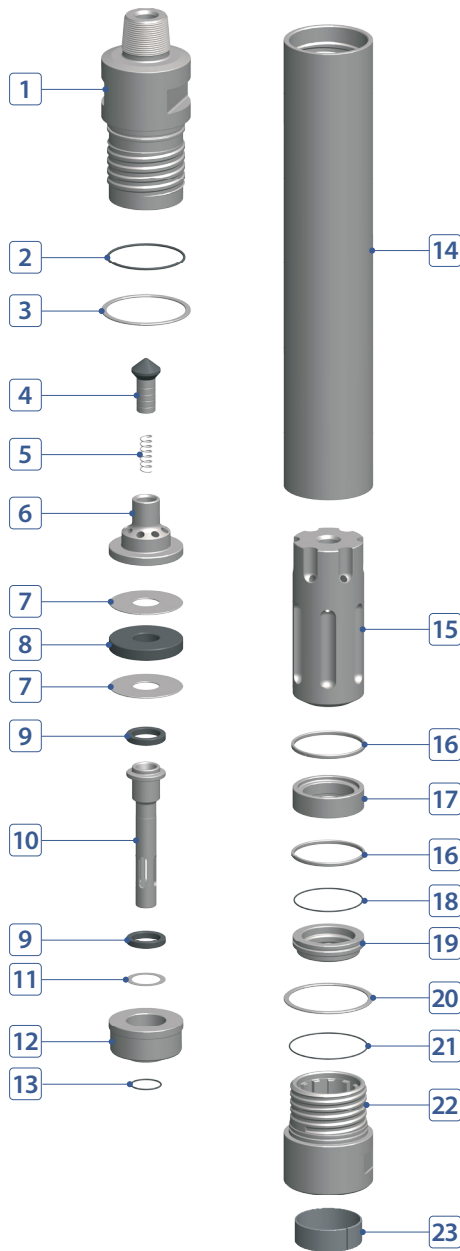

COMPONENT PART



| No. | DESCRIPTION | Q'TY | PART # |
|-----|-----------------------------|------|----------------|
| 1 | Back Head | 1 | T120-01-A01FRP |
| 2 | Back Head O-Ring | 1 | T120-01-A03000 |
| 3 | Breakout Washer (Back Head) | 1 | T120-01-A02000 |
| 4 | Air Check Valve | 1 | T120-01-A09000 |
| 5 | Air Check Valve Spring | 1 | T120-01-A10000 |
| 6 | Air Guide | 1 | T120-01-A11000 |
| 7 | Buffering Washer | 2 | T120-01-A05000 |
| 8 | Make-up Ring (Buffering) | 1 | T120-01-A07000 |
| 9 | Tube Buffering | 2 | T120-01-A21000 |
| 10 | Feed Tube | 1 | T120-01-A23000 |
| 11 | Tube Buffering Washer | 1 | T120-01-A22000 |
| 12 | Tube Guide | 1 | T120-01-A19000 |
| 13 | Tube Guide O-Ring | 1 | T120-01-A20000 |
| 14 | Wear Sleeve | 1 | T120-01-A25000 |
| 15 | Piston | 1 | T120-01-A26000 |
| 16 | Piston Stop Ring | 2 | T120-01-A29000 |
| 17 | Bearing | 1 | T120-01-A31000 |
| 18 | Bit Retainer O-Ring | 1 | T120-01-A37000 |
| 19 | Bit Retainer | 1 | T120-01-A36000 |
| 20 | Breakout Washer (Chuck) | 1 | T120-01-A39000 |
| 21 | Chuck O-Ring | 1 | T120-01-A40000 |
| 22 | Chuck | 1 | T120-01-A41000 |
| 23 | Chuck Bushing | 1 | T120-01-A54000 |

HAMMER SPECIFICATIONS

| | | |
|------------------------|-------------------------|--------------|
| Length (w/o drill bit) | 70.59" | 1,793 mm |
| Outside Diameter | 10.62" | 270 mm |
| Weight | 1,283 lbs. | 582 kg |
| Piston Weight | 252 lbs. | 114.3 kg |
| Hole Size | 12" ~ 17-1/2" | 304 ~ 445 mm |
| Connection | Std. 6-5/8" API Reg Pin | |

AIR CONSUMPTION CHART

