

COMPONENT PART

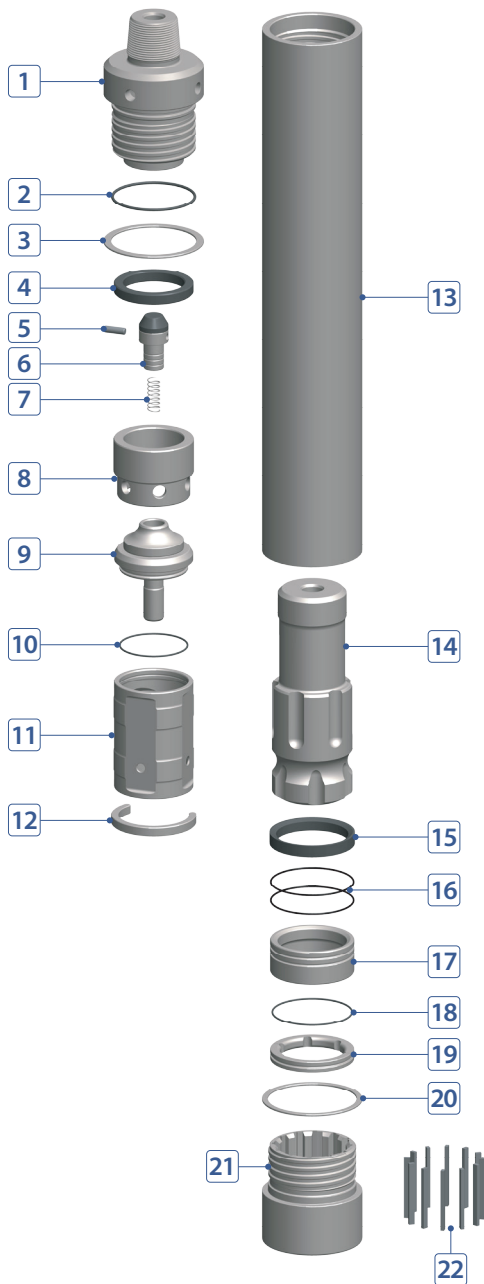

No.	DESCRIPTION	Q'TY	PART #
1	Back Head	1	W120-02-A01FRP
2	Back Head O-Ring	1	W120-02-A03000
3	Back Head Washer	1	W120-02-A02000
4	Buffering	1	W120-02-A07000
5	Choke	1	W120-02-A08000
6	Air Check Valve	1	W120-02-A09000
7	Air Check Valve Spring	1	W120-02-A10000
8	Air Guide	1	W120-02-A11000
9	Air Distributor	1	W120-02-A15000
10	Air Distributor O-Ring	1	W120-02-A16000
11	Cylinder	1	W120-02-A17000
12	Cylinder Stop Ring (Steel)	1	W120-02-A43000
13	Wear Sleeve	1	W120-02-A25QLK
14	Piston	1	W120-02-A26QLK
15	Piston Stop Ring (Buffering)	1	W120-02-A28000
16	Bearing O-Ring	2	W120-02-A32000
17	Bearing	1	W120-02-A31QLK
18	Bit Retainer O-Ring	1	W120-02-A37000
19	Bit Retainer	1	W120-02-A36QLK
20	Chuck Washer	1	W120-02-A39QLK
21	Chuck	1	W120-02-A41QLK
22	Drive Pin	12	W120-02-A44QLK

HAMMER SPECIFICATIONS

Length (w/o drill bit)	69.68"	1,770 mm
Outside Diameter	10.78"	274 mm
Weight	1,272 lbs.	577 kg
Piston Weight	287.5 lbs.	130.4 kg
Hole Size	12" ~ 17-1/2"	302 ~ 445 mm
Connection	Std. 6-5/8" API Reg Pin	

AIR CONSUMPTION CHART

