

DTH HAMMER

WCH120 12" HAMMER WITH NUMA120 SHANK

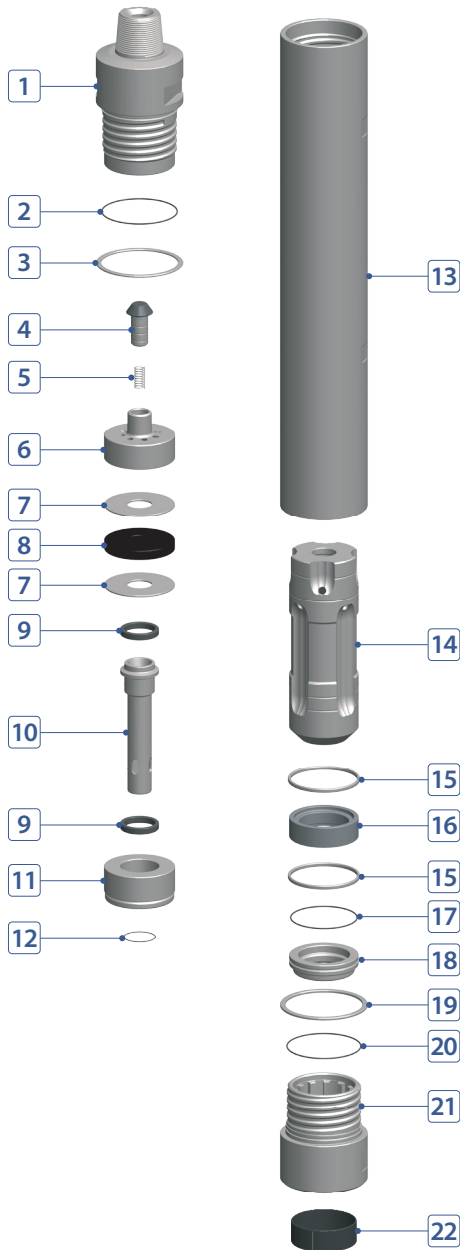

COMPONENT PART



No.	DESCRIPTION	Q'TY	PART #
1	Back Head	1	H121-01-A01FRP
2	Back Head O-Ring	1	H121-01-A03000
3	Back Head Washer	1	H121-01-A02NUM
4	Air Check Valve	1	H121-01-A09NUM
5	Air Check Valve Spring	1	H121-01-A10NUM
6	Air Diverter	1	H121-01-A57NUM
7	Compression Buffer Washer	2	H121-01-A05NUM
8	Compression Buffer	1	H121-01-A07NUM
9	Tube Buffering	2	H121-01-A21NUM
10	Control Tube	1	H121-01-A23NUM
11	Control Tube Holder	1	H121-01-A19NUM
12	Tube Holder O-Ring	1	H121-01-A20000
13	Wear Sleeve	1	H121-01-A25NUM
14	Piston	1	H121-01-A26NUM
15	Piston Stop Ring (Steel)	2	H121-01-A29NUM
16	Bearing	1	H121-01-A31NUM
17	Bit Retainer O-Ring	1	H121-01-A37000
18	Bit Retainer	1	H121-01-A36NUM
19	Chuck Washer	1	H121-01-A39NUM
20	Chuck O-Ring	1	H121-01-A40000
21	Chuck	1	H121-01-A41NUM
22	Chuck Bushing	1	H121-01-A54NUM

HAMMER SPECIFICATIONS

Length (w/o drill bit)	74.17"	1,884 mm
Outside Diameter	10.7"	272 mm
Weight	1,361 lbs.	617 kg
Piston Weight	273.5 lbs.	124 kg
Hole Size	12" ~ 17-1/2"	304 ~ 445 mm
Connection	Std. 6-5/8" API Reg Pin	

AIR CONSUMPTION CHART

