

DTH HAMMER

KSS120 12" HAMMER WITH SD12 SHANK

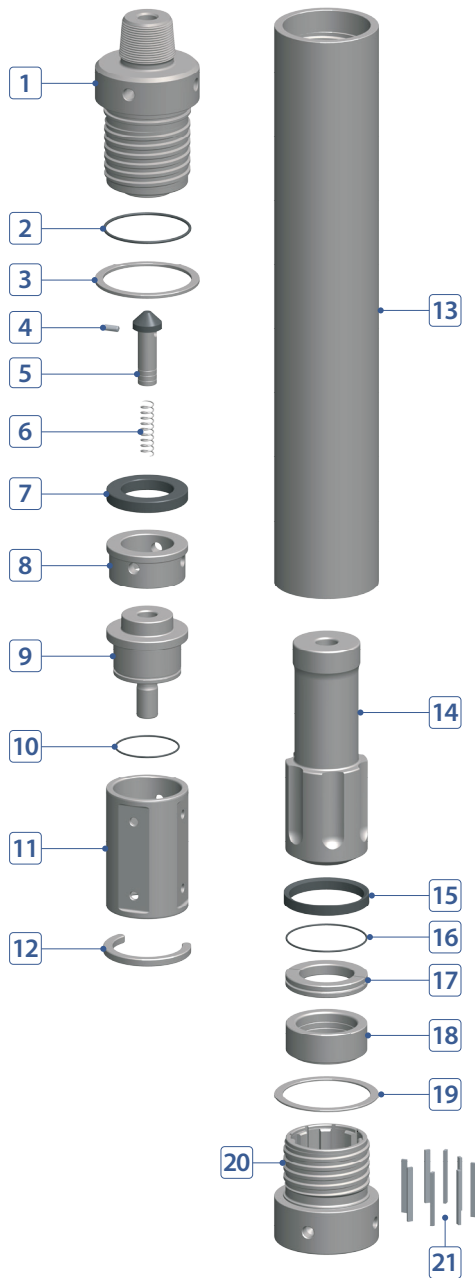

COMPONENT PART



No.	DESCRIPTION	Q'TY	PART #
1	Back Head	1	K120-02-A01FRP
2	Back Head O-Ring	1	K120-02-A03000
3	Back Head Washer	1	K120-02-A02000
4	Plug (Choke)	1	K120-02-A08000
5	Air Check Valve	1	K120-02-A09000
6	Air Check Valve Spring	1	K120-02-A10000
7	Buffering	1	K120-02-A07000
8	Air Guide	1	K120-02-A11000
9	Air Distributor	1	K120-02-A15000
10	Air Distributor O-Ring	1	K120-02-A16000
11	Cylinder	1	K120-02-A17000
12	Cylinder Stop Ring (Key)	1	K120-02-A43000
13	Wear Sleeve	1	K120-02-A25SIN
14	Piston	1	K120-02-A26SIK
15	Piston Stop Ring (Buffering)	1	K120-02-A28000
16	Bit Retainer O-Ring	1	K120-02-A37000
17	Bit Retainer	1	K120-02-A36SDK
18	Guide Sleeve	1	K120-02-A38SDK
19	Chuck Washer	1	K120-02-A39000
20	Chuck	1	K120-02-A41SDK
21	Drive Pin	8	K120-02-A44SDK

HAMMER SPECIFICATIONS

Length (w/o drill bit)	70.11"	1,781 mm
Outside Diameter	10.78"	274 mm
Weight	1,375 lbs.	623.5 kg
Piston Weight	258.4 lbs.	117.2 kg
Hole Size	12" ~ 17-1/2"	304 ~ 445 mm
Connection	Std. 6-5/8" API Reg Pin	

AIR CONSUMPTION CHART

