

DTH HAMMER

KSI120 12" HAMMER WITH DHD112 SHANK

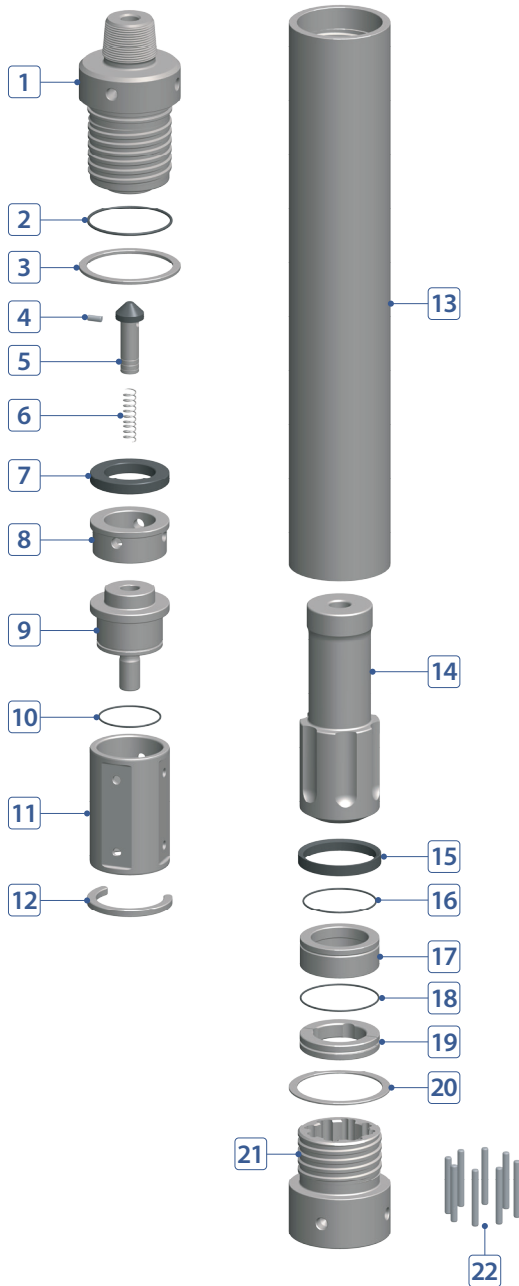

COMPONENT PART



No.	DESCRIPTION	Q'TY	PART #
1	Back Head	1	K120-02-A01FRP
2	Back Head O-Ring	1	K120-02-A03000
3	Back Head Washer	1	K120-02-A02000
4	Plug (Choke)	1	K120-02-A08000
5	Air Check Valve	1	K120-02-A09000
6	Air Check Valve Spring	1	K120-02-A10000
7	Buffering	1	K120-02-A07000
8	Air Guide	1	K120-02-A11000
9	Air Distributor	1	K120-02-A15000
10	Air Distributor O-Ring	1	K120-02-A16000
11	Cylinder	1	K120-02-A17000
12	Cylinder Stop Ring (Key)	1	K120-02-A43000
13	Wear Sleeve	1	K120-02-A25SIN
14	Piston	1	K120-02-A26SIK
15	Piston Stop Ring (Buffering)	1	K120-02-A28000
16	Bearing O-Ring	1	K120-02-A32000
17	Bearing	1	K120-02-A31DHD
18	Bit Retainer O-Ring	1	K120-02-A37000
19	Bit Retainer	1	K120-02-A36DHD
20	Chuck Washer	1	K120-02-A39000
21	Chuck	1	K120-02-A41DHD
22	Drive Pin	8	K120-02-A44DHD

HAMMER SPECIFICATIONS

Length (w/o drill bit)	71"	1,804 mm
Outside Diameter	10.78"	274 mm
Weight	1,394.5 lbs.	632.5 kg
Piston Weight	258.4 lbs.	117.2 kg
Hole Size	12" ~ 17-1/2"	304 ~ 445 mm
Connection	Std. 6-5/8" API Reg Pin	

AIR CONSUMPTION CHART

