

DTH HAMMER

WCS1001 10" HAMMER WITH SD10 SHANK



[NO FOOT VALVE TYPE]

COMPONENT PART

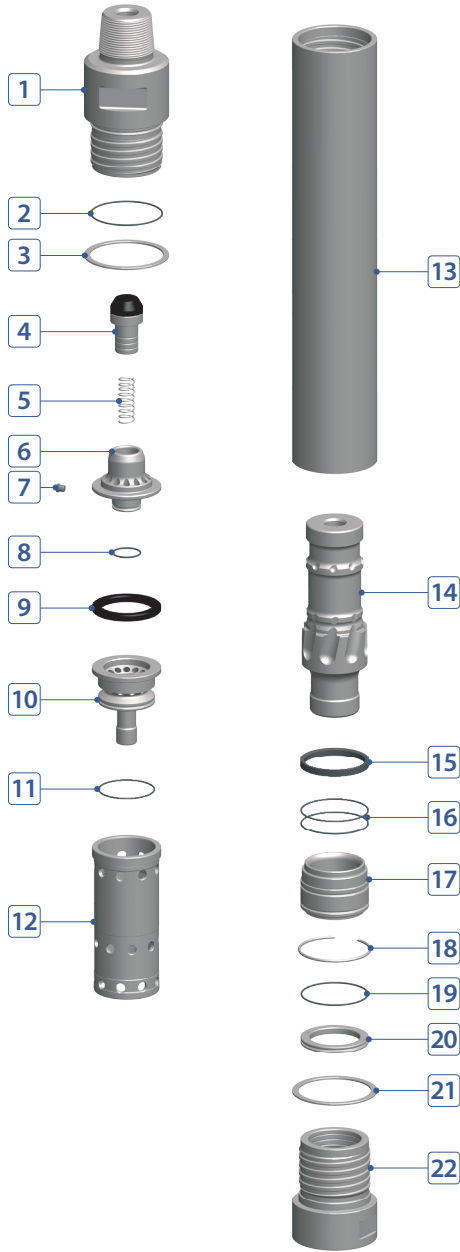

No.	DESCRIPTION	Q'TY	PART #
1	Back Head	1	T100-02-A01FRP
2	Back Head O-Ring	1	T100-02-A03000
3	Back Head Washer	1	T100-02-A02000
4	Air Check Valve	1	T100-02-A09000
5	Air Check Valve Spring	1	T100-02-A10000
6	Air Guide	1	T100-02-A11000
7	Air Guide Plug (Choke)	1	T100-02-A13000
8	Air Guide O-Ring	1	T100-02-A14000
9	Buffering	1	T100-02-A07000
10	Air Distributor	1	T100-02-A15000
11	Air Distributor O-Ring	1	T100-02-A16000
12	Cylinder	1	T100-02-A17000
13	Wear Sleeve	1	T100-02-A25SDK
14	Piston	1	T100-02-A26000
15	Piston Stop Ring	1	T100-02-A28000
16	Bearing O-Ring	2	T100-02-A32000
17	Bearing	1	T100-02-A31SDK
18	Bearing Stop Ring	1	T100-02-A34SDK
19	Bit Retainer O-Ring	1	T100-02-A37000
20	Bit Retainer	1	T100-02-A36SDK
21	Chuck Washer	1	T100-02-A39SDK
22	Chuck	1	T100-02-A41SDK

HAMMER SPECIFICATIONS

Length (w/o drill bit)	57.3"	1,455.5 mm
Outside Diameter	8.85"	225 mm
Weight	692.3 lbs.	314 kg
Piston Weight	133.5 lbs.	60.5 kg
Hole Size	10" ~ 14"	254 ~ 356 mm
Connection	Std. 6-5/8" API Reg Pin	

AIR CONSUMPTION CHART

