

COMPONENT PART

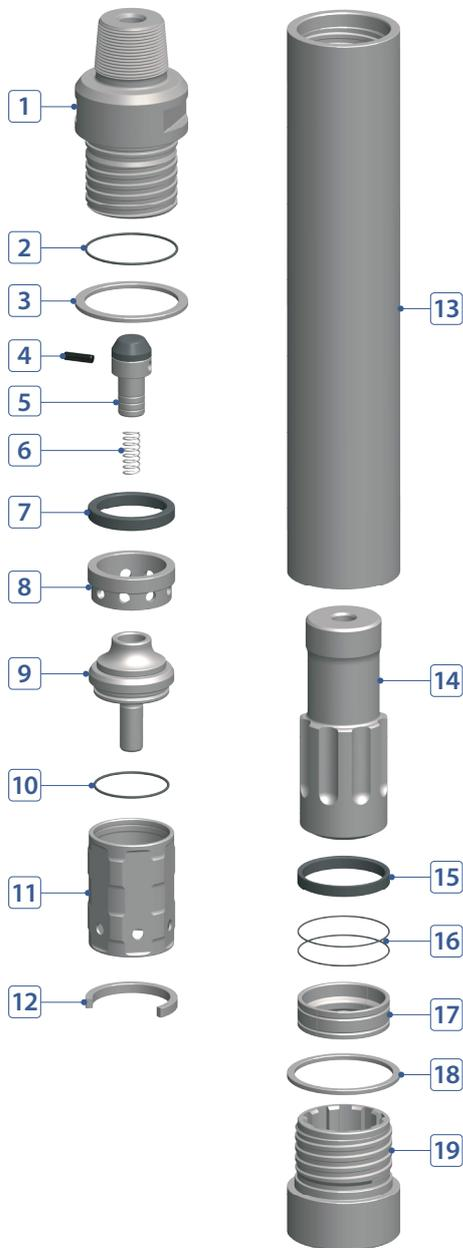

No.	DESCRIPTION	Q'TY	PART #
1	Back Head	1	W100-02-A01FRP
2	Back Head O-Ring	1	W100-02-A03000
3	Back Head Washer	1	W100-02-A02000
4	Air Check Valve Plug	1	W100-02-A08000
5	Air Check Valve	1	W100-02-A09000
6	Air Check Valve Spring	1	W100-02-A10000
7	Buffering	1	W100-02-A07000
8	Air Guide	1	W100-02-A11000
9	Air Distributor	1	W100-02-A15000
10	Air Distributor O-Ring	1	W100-02-A16000
11	Cylinder	1	W100-02-A17000
12	Cylinder Stop Ring (Steel)	1	W100-02-A43000
13	Wear Sleeve	1	W100-02-A25000
14	Piston	1	W100-02-A26000
15	Piston Stop Ring (Buffering)	1	W100-02-A28000
16	Bit Retainer O-Ring	2	W100-02-A37000
17	Bit Retainer	1	W100-02-A36NUM
18	Chuck Washer	1	W100-02-A39000
19	Chuck	1	W100-02-A41NUM

HAMMER SPECIFICATIONS

Length (w/o drill bit)	54.37"	1,381 mm
Outside Diameter	8.85"	225 mm
Weight	692.3 lbs.	314 kg
Piston Weight	136.7 lbs.	62 kg
Hole Size	10" ~ 14.01"	254 ~ 356 mm
Connection	Std. 6-5/8" API Reg Pin	

AIR CONSUMPTION CHART

