

DTH HAMMER

KSS100 10" HAMMER WITH SD10 SHANK

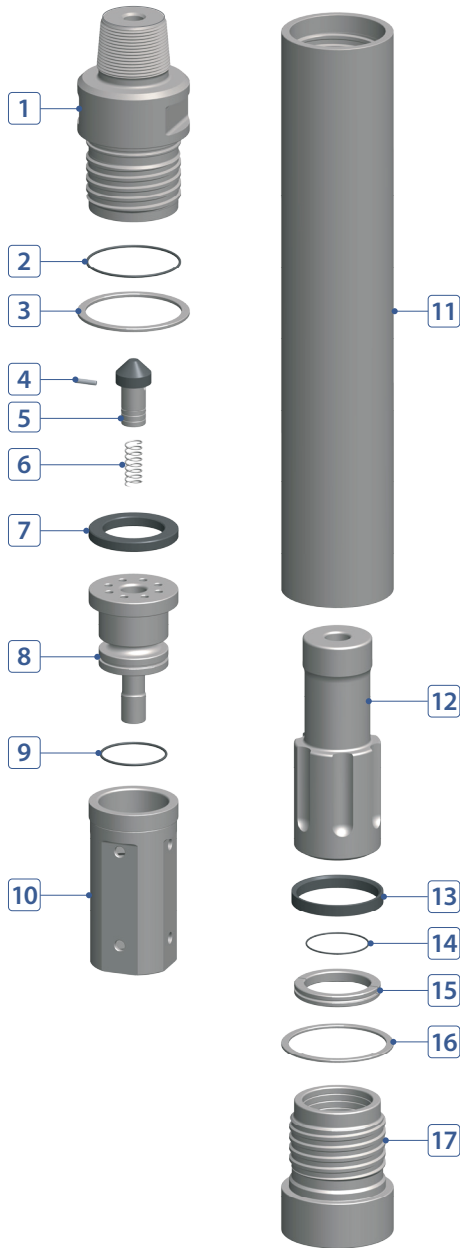

COMPONENT PART



No.	DESCRIPTION	Q'TY	PART #
1	Back Head	1	K100-02-A01FRP
2	Back Head O-Ring	1	K100-02-A03000
3	Back Head Washer	1	K100-02-A02000
4	Plug (Choke)	1	K100-02-A08000
5	Air Check Valve	1	K100-02-A09000
6	Air Check Valve Spring	1	K100-02-A10000
7	Buffering	1	K100-02-A07000
8	Air Distributor	1	K100-02-A15000
9	Air Distributor O-Ring	1	K100-02-A16000
10	Cylinder	1	K100-02-A17000
11	Wear Sleeve	1	K100-02-A25SDK
12	Piston	1	K100-02-A26SNK
13	Piston Stop Ring (Buffering)	1	K100-02-A28SDK
14	Bit Retainer O-Ring	1	K100-02-A37000
15	Bit Retainer	1	K100-02-A36SDK
16	Chuck Washer	1	K100-02-A39SDK
17	Chuck	1	K100-02-A41SDK

HAMMER SPECIFICATIONS

Length (w/o drill bit)	55.33"	1,405.5 mm
Outside Diameter	8.85"	225 mm
Weight	732.4 lbs.	332.2 kg
Piston Weight	126.6 lbs.	57.4 kg
Hole Size	10" ~ 14"	254 ~ 356 mm
Connection	Std. 6-5/8" API Reg Pin	

AIR CONSUMPTION CHART

